

# UNIT 4

## Advanced Expressions and Data Analysis

### Focus

Use a variety of representations, tools, and technology to model mathematical situations to solve meaningful problems.

### CHAPTER 10

#### Radical Expressions and Triangles

**BIG Idea** Use algebraic skills to simplify radical expressions and solve equations in problem situations.

### CHAPTER 11 Rational Expressions and Equations

**BIG Idea** Use algebraic skills to simplify rational expressions and solve equations.

### CHAPTER 12

#### Statistics and Probability

**BIG Idea** Use graphical and numerical techniques to study patterns and analyze data.

**BIG Idea** Use probability models to describe everyday situations involving chance.



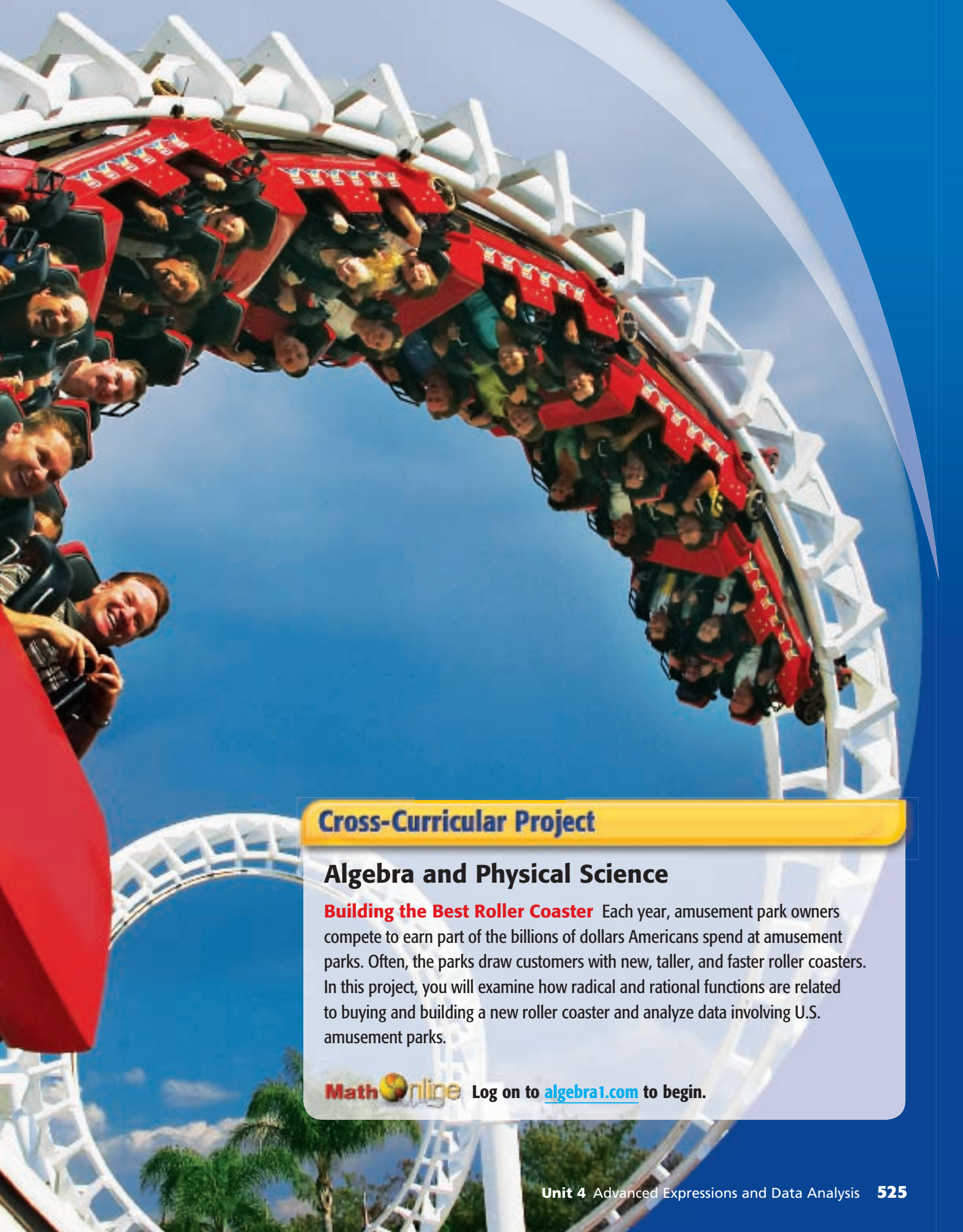

## Cross-Curricular Project

### Algebra and Physical Science

**Building the Best Roller Coaster** Each year, amusement park owners compete to earn part of the billions of dollars Americans spend at amusement parks. Often, the parks draw customers with new, taller, and faster roller coasters. In this project, you will examine how radical and rational functions are related to buying and building a new roller coaster and analyze data involving U.S. amusement parks.

**Math**  **Online** Log on to [algebra1.com](http://algebra1.com) to begin.

# Radical Expressions and Triangles

## BIG Ideas

- Simplify and perform operations with radical expressions.
- Solve radical equations.
- Use the Pythagorean Theorem and Distance Formula.
- Use similar triangles and trigonometric ratios.

## Key Vocabulary

- Distance Formula (p. 555)
- Pythagorean triple (p. 550)
- radical equation (p. 541)
- radical expression (p. 528)

## Real-World Link

**Skydiving** Physics problems are among the many applications of radical equations. Formulas that contain the value for the acceleration due to gravity, such as free-fall times, can be written as radical equations.

## FOLDABLES™ Study Organizer

**Radical Expressions and Triangles** Make this Foldable to help you organize your notes.

Begin with one  $8\frac{1}{2}$ " by 11" paper.

- 1 Fold** in half matching the short sides.



- 2 Unfold** and fold the long side up 2 inches to form a pocket.



- 3 Staple** or glue the outer edges to complete the pocket.



- 4 Label** each side as shown. Use index cards to record examples.

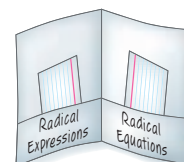

# GET READY for Chapter 10

**Diagnose Readiness** You have two options for checking Prerequisite Skills.

## Option 2



Take the Online Readiness Quiz at [algebra1.com](http://algebra1.com).

## Option 1

Take the Quick Check below. Refer to the Quick Review for help.

### QUICK Check

Find each square root. If necessary, round to the nearest hundredth. (Lesson 1-8)

1.  $\sqrt{25}$       2.  $\sqrt{80}$       3.  $\sqrt{56}$

4. **PAINTING** Todd is painting a square mural with an area of 81 square feet. What is the length of the side of the mural?

Simplify each expression. (Lesson 1-6)

5.  $(10c - 5d) + (6c + 5d)$

6.  $3a + 7b - 2a$

7.  $(21m + 15n) - (9n - 4m)$

8.  $14x - 6y + 2y$

Solve each equation. (Lesson 8-3)

9.  $x^2 + 10x + 24 = 0$     10.  $2x^2 + x + 1 = 2$

11. **GEOMETRY** The triangle has an area of 120 square centimeters. Find  $h$ .

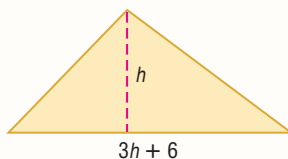

Use cross products to determine whether each pair of ratios forms a proportion.

Write *yes* or *no*. (Lesson 2-6)

12.  $\frac{2}{3} \text{ ' } \frac{8}{12}$     13.  $\frac{4}{5} \text{ ' } \frac{16}{25}$     14.  $\frac{8}{10} \text{ ' } \frac{12}{16}$

15. **MODELS** A collector's model train is scaled so that 1 inch on the model equals 3.5 feet on the actual train. If the model is 3.25 inches tall, how tall is the actual train?

### QUICK Review

#### EXAMPLE 1

Find the square root of  $\sqrt{82}$ . If necessary, round to the nearest hundredth.

$\sqrt{82} = 9.05538513814\dots$  Use a calculator.

To the nearest hundredth,  $\sqrt{82} \approx 9.06$ .

#### EXAMPLE 2

Simplify  $6m + 3 + 2k - 17b - 100 - 16k + 8b + m$ .

$$\begin{aligned} 6m + 3 + 2k - 17b - 100 - 16k + 8b + m \\ = (6m + m) + (2k - 16k) + (8b - 17b) + \\ (3 - 100) \\ = 7m - 14k - 9b - 97 \quad \text{Simplify.} \end{aligned}$$

#### EXAMPLE 3

Solve  $3x^2 + 4x - 4 = 0$ .

$$\begin{aligned} 3x^2 + 4x - 4 &= 0 && \text{Original equation} \\ (3x - 2)(x + 2) &= 0 && \text{Factor.} \\ (3x - 2) = 0 \text{ or } (x + 2) = 0 &&& \text{Zero Product Property} \\ x = \frac{2}{3} \text{ or } x = -2 &&& \text{Solve each equation.} \end{aligned}$$

#### EXAMPLE 4

Use cross products to determine whether  $\frac{5}{8}$  and  $\frac{60}{96}$  form a proportion. Write *yes* or *no*.

$$\begin{aligned} \frac{5}{8} \stackrel{?}{=} \frac{60}{96} &&& \text{Write the equation.} \\ 5(96) \stackrel{?}{=} 8(60) &&& \text{Find the cross products.} \\ 480 = 480 &&& \text{Simplify. They form a proportion.} \end{aligned}$$

# Simplifying Radical Expressions

## Main Ideas

- Simplify radical expressions using the Product Property of Square Roots.
- Simplify radical expressions using the Quotient Property of Square Roots.

## New Vocabulary

radical expression  
radicand  
rationalizing the denominator  
conjugate

### GET READY for the Lesson

A spacecraft leaving Earth must have a velocity of at least 11.2 kilometers per second (25,000 miles per hour) to enter into orbit. This velocity is called the *escape velocity*. The escape velocity of an object is given by the radical expression  $\sqrt{\frac{2GM}{R}}$ , where  $G$  is the gravitational constant,  $M$  is the mass of the planet or star, and  $R$  is the radius of the planet or star. Once values are substituted for the variables, the formula can be simplified.



**Product Property of Square Roots** A **radical expression** is an expression that contains a square root, such as  $\sqrt{\frac{2GM}{R}}$ . A **radicand**, the expression under the radical sign, is in simplest form if it contains no perfect square factors other than 1. The following property can be used to simplify square roots.

### KEY CONCEPT

### Product Property of Square Roots

**Words** For any numbers  $a$  and  $b$ , where  $a \geq 0$  and  $b \geq 0$ , the square root of the product  $ab$  is equal to the product of each square root.

**Symbols**  $\sqrt{ab} = \sqrt{a} \cdot \sqrt{b}$

**Example**  $\sqrt{4 \cdot 25} = \sqrt{4} \cdot \sqrt{25}$

## Reading Math

### Radical Expressions

$2\sqrt{3}$  is read *two times the square root of 3* or *two radical three*.

### EXAMPLE Simplify Square Roots

1 Simplify  $\sqrt{90}$ .

$$\begin{aligned}\sqrt{90} &= \sqrt{2 \cdot 3 \cdot 3 \cdot 5} && \text{Prime factorization of 90} \\ &= \sqrt{3^2} \cdot \sqrt{2 \cdot 5} && \text{Product Property of Square Roots} \\ &= 3\sqrt{10} && \text{Simplify.}\end{aligned}$$

### CHECK Your Progress

Simplify.

1A.  $\sqrt{27}$

1B.  $\sqrt{150}$

## Study Tip

### Alternative Method

To find  $\sqrt{3} \cdot \sqrt{15}$ , you could multiply first and then use the prime factorization.

$$\begin{aligned}\sqrt{3} \cdot \sqrt{15} &= \sqrt{45} \\ &= \sqrt{3^2 \cdot 5} \\ &= 3\sqrt{5}\end{aligned}$$

## EXAMPLE Multiply Square Roots

2 Simplify  $\sqrt{3} \cdot \sqrt{15}$ .

$$\begin{aligned}\sqrt{3} \cdot \sqrt{15} &= \sqrt{3} \cdot \sqrt{3} \cdot \sqrt{5} && \text{Product Property of Square Roots} \\ &= \sqrt{3^2} \cdot \sqrt{5} \text{ or } 3\sqrt{5} && \text{Product Property; then simplify.}\end{aligned}$$

**CHECK Your Progress** Simplify.

2A.  $\sqrt{5} \cdot \sqrt{10}$

2B.  $\sqrt{6} \cdot \sqrt{8}$

When finding the principal square root of an expression containing variables, be sure that the result is not negative. Consider the expression  $\sqrt{x^2}$ . It may seem that  $\sqrt{x^2} = x$ . Let's look at  $x = -2$ .

$$\begin{aligned}\sqrt{x^2} &\stackrel{?}{=} x \\ \sqrt{(-2)^2} &\stackrel{?}{=} -2 && \text{Replace } x \text{ with } -2. \\ \sqrt{4} &\stackrel{?}{=} -2 && (-2)^2 = 4 \\ 2 &\neq -2 && \sqrt{4} = 2\end{aligned}$$

For radical expressions where the exponent of the variable inside the radical is even and the resulting simplified exponent is odd, you must use absolute value to ensure nonnegative results.

$$\sqrt{x^2} = |x| \quad \sqrt{x^3} = |x| \sqrt{x} \quad \sqrt{x^4} = x^2 \quad \sqrt{x^5} = x^2 \sqrt{x} \quad \sqrt{x^6} = |x^3|$$

## EXAMPLE Simplify a Square Root with Variables

3 Simplify  $\sqrt{40x^4y^5z^3}$ .

$$\begin{aligned}\sqrt{40x^4y^5z^3} &= \sqrt{2^3 \cdot 5 \cdot x^4 \cdot y^5 \cdot z^3} && \text{Prime factorization} \\ &= \sqrt{2^2} \cdot \sqrt{2} \cdot \sqrt{5} \cdot \sqrt{x^4} \cdot \sqrt{y^4} \cdot \sqrt{y} \cdot \sqrt{z^2} \cdot \sqrt{z} && \text{Product Property} \\ &= 2 \cdot \sqrt{2} \cdot \sqrt{5} \cdot x^2 \cdot y^2 \cdot \sqrt{y} \cdot |z| \cdot \sqrt{z} && \text{Simplify.} \\ &= 2x^2y^2|z|\sqrt{10yz} && \text{The absolute value of } z \text{ ensures a nonnegative result.}\end{aligned}$$

**CHECK Your Progress** Simplify.

3A.  $\sqrt{32r^2s^4t^5}$

3B.  $\sqrt{56xy^{10}z^5}$

**Quotient Property of Square Roots** You can divide square roots and simplify radical expressions by using the Quotient Property of Square Roots.

## KEY CONCEPT

### Quotient Property of Square Roots

**Words** For any numbers  $a$  and  $b$ , where  $a \geq 0$  and  $b > 0$ , the square root of the quotient  $\frac{a}{b}$  is equal to the quotient of each square root.

**Symbols**  $\sqrt{\frac{a}{b}} = \frac{\sqrt{a}}{\sqrt{b}}$

**Example**  $\sqrt{\frac{49}{4}} = \frac{\sqrt{49}}{\sqrt{4}}$



## Study Tip

### Look Back

To review the **Quadratic Formula**, see Lesson 9-4.

## Study Tip

### Plus or Minus Symbols

The  $\pm$  symbol is used with the radical expression since both square roots lead to solutions.

You can use the Quotient Property of Square Roots to derive the Quadratic Formula by solving the quadratic equation  $ax^2 + bx + c = 0$ .

$$ax^2 + bx + c = 0$$

Original equation.

$$x^2 + \frac{b}{a}x + \frac{c}{a} = 0$$

Divide each side by  $a$ ,  $a \neq 0$ .

$$x^2 + \frac{b}{a}x = -\frac{c}{a}$$

Subtract  $\frac{c}{a}$  from each side.

$$x^2 + \frac{b}{a}x + \frac{b^2}{4a^2} = -\frac{c}{a} + \frac{b^2}{4a^2}$$

Complete the square;  $\left(\frac{b}{2a}\right)^2 = \frac{b^2}{4a^2}$ .

$$\left(x + \frac{b}{2a}\right)^2 = \frac{-4ac + b^2}{4a^2}$$

Factor  $x^2 + \frac{b}{a}x + \frac{b^2}{4a^2}$ .

$$\left|x + \frac{b}{2a}\right| = \sqrt{\frac{b^2 - 4ac}{4a^2}}$$

Take the square root of each side.

$$x + \frac{b}{2a} = \pm \sqrt{\frac{b^2 - 4ac}{4a^2}}$$

Remove the absolute value symbols and insert  $\pm$ .

$$x + \frac{b}{2a} = \pm \frac{\sqrt{b^2 - 4ac}}{\sqrt{4a^2}}$$

Quotient Property of Square Roots

$$x + \frac{b}{2a} = \pm \frac{\sqrt{b^2 - 4ac}}{2a}$$

$$\sqrt{4a^2} = 2a$$

$$x = \frac{-b \pm \sqrt{b^2 - 4ac}}{2a}$$

Subtract  $\frac{b}{2a}$  from each side.

If no prime factors with an exponent greater than 1 appear under the radical sign and if no radicals are left in the denominator, then a fraction containing radicals is in simplest form. **Rationalizing the denominator** of a radical expression is a method used to eliminate radicals from a denominator.

## EXAMPLE Rationalizing the Denominator

### 4 Simplify.

a.  $\sqrt{\frac{10}{3}}$

b.  $\frac{\sqrt{2n}}{\sqrt{6}}$

$$\sqrt{\frac{10}{3}} = \frac{\sqrt{10}}{\sqrt{3}}$$

Quotient Property of Square Roots

$$= \frac{\sqrt{10}}{\sqrt{3}} \cdot \frac{\sqrt{3}}{\sqrt{3}}$$

Multiply by  $\frac{\sqrt{3}}{\sqrt{3}}$ .

$$= \frac{\sqrt{30}}{3}$$

Product Property of Square Roots

$$\frac{\sqrt{2n}}{\sqrt{6}} = \frac{\sqrt{2n}}{\sqrt{6}} \cdot \frac{\sqrt{6}}{\sqrt{6}}$$

Multiply by  $\frac{\sqrt{6}}{\sqrt{6}}$ .

$$= \frac{\sqrt{12n}}{6}$$

Product Property of Square Roots

$$= \frac{\sqrt{2 \cdot 2 \cdot 3 \cdot n}}{6}$$

Prime factorization

$$= \frac{2\sqrt{3n}}{6}$$

$$\sqrt{2^2} = 2$$

$$= \frac{\sqrt{3n}}{3}$$

Divide numerator and denominator by 2.

## Study Tip

### Calculator

Approximations for radical expressions are often used when solving real-world problems. The

expression  $\frac{\sqrt{30}}{3}$  can be approximated by pressing  $\boxed{2\text{nd}} \boxed{[\sqrt{\quad}]}$

$30 \boxed{)} \boxed{\div} \boxed{3}$

$\boxed{\text{ENTER}}$

## CHECK Your Progress

4A.  $\frac{\sqrt{14}}{\sqrt{5}}$

4B.  $\frac{\sqrt{6y}}{\sqrt{12}}$

Binomials of the form  $p\sqrt{q} + r\sqrt{s}$  and  $p\sqrt{q} - r\sqrt{s}$  are called **conjugates**. For example,  $3 + \sqrt{2}$  and  $3 - \sqrt{2}$  are conjugates. Conjugates are useful when simplifying radical expressions because if  $p$ ,  $q$ ,  $r$ , and  $s$  are rational numbers, the product of the two conjugates is a rational number. Use the pattern for the difference of squares  $(a - b)(a + b) = a^2 - b^2$  to find their product.

$$\begin{aligned}(3 + \sqrt{2})(3 - \sqrt{2}) &= 3^2 - (\sqrt{2})^2 & a = 3, b = \sqrt{2} \\ &= 9 - 2 \text{ or } 7 & (\sqrt{2})^2 = \sqrt{2} \cdot \sqrt{2} \text{ or } 2\end{aligned}$$

### EXAMPLE Use Conjugates to Rationalize a Denominator

5 Simplify  $\frac{2}{6 - \sqrt{3}}$ .

$$\begin{aligned}\frac{2}{6 - \sqrt{3}} &= \frac{2}{6 - \sqrt{3}} \cdot \frac{6 + \sqrt{3}}{6 + \sqrt{3}} & \frac{6 + \sqrt{3}}{6 + \sqrt{3}} &= 1; \text{ The conjugate of } 6 - \sqrt{3} \text{ is } 6 + \sqrt{3}. \\ &= \frac{2(6 + \sqrt{3})}{6^2 - (\sqrt{3})^2} & (a - b)(a + b) &= a^2 - b^2 \\ &= \frac{12 + 2\sqrt{3}}{36 - 3} & (\sqrt{3})^2 &= 3 \\ &= \frac{12 + 2\sqrt{3}}{33} & \text{Simplify.}\end{aligned}$$

#### Cross-Curricular Project



The speed of a roller coaster can be determined by evaluating a radical expression. Visit [algebra1.com](http://algebra1.com) to continue work on your project.

### CHECK Your Progress Simplify.

5A.  $\frac{3}{2 + \sqrt{2}}$

5B.  $\frac{7}{3 - \sqrt{7}}$

Personal Tutor at [algebra1.com](http://algebra1.com)

When simplifying radical expressions, check the following conditions to determine if the expression is in simplest form.

### CONCEPT SUMMARY

#### Simplest Radical Form

A radical expression is in simplest form when the following three conditions have been met.

1. No radicands have perfect square factors other than 1.
2. No radicands contain fractions.
3. No radicals appear in the denominator of a fraction.

### CHECK Your Understanding

Examples 1, 2  
(pp. 528–529)

Simplify.

1.  $\sqrt{20}$

2.  $\sqrt{52}$

3.  $2\sqrt{32}$

4.  $\sqrt{2} \cdot \sqrt{8}$

5.  $\sqrt{3} \cdot \sqrt{18}$

6.  $3\sqrt{10} \cdot 4\sqrt{10}$

7. **GEOMETRY** A square has sides measuring  $2\sqrt{7}$  feet each. Determine the area of the square.



**Examples 3, 4**  
(pp. 529–530)

**Simplify.**

8.  $\sqrt{54a^2b^2}$       9.  $\sqrt{60x^5y^6}$       10.  $\sqrt{88m^3n^2p^5}$   
 11.  $\frac{4}{\sqrt{6}}$       12.  $\sqrt{\frac{3}{10}}$       13.  $\sqrt{\frac{7}{2}} \cdot \sqrt{\frac{5}{3}}$

14. **PHYSICS** The period of a pendulum is the time required for it to make one complete swing back and forth. The formula of the period  $P$  of a pendulum is  $P = 2\pi\sqrt{\frac{\ell}{32}}$ , where  $\ell$  is the length of the pendulum in feet. If a pendulum in a clock tower is 8 feet long, find the period. Use 3.14 for  $\pi$ .



**Example 5**  
(p. 531)

**Simplify.**

15.  $\frac{8}{3 - \sqrt{2}}$       16.  $\frac{2\sqrt{5}}{-4 + \sqrt{8}}$

**Exercises**

HOMEWORK HELP	
For Exercises	See Examples
17–20	1
21–24	2
25–28	3
29–34	4
35–40	5

**Simplify.**

17.  $\sqrt{18}$       18.  $\sqrt{24}$       19.  $\sqrt{80}$   
 20.  $\sqrt{75}$       21.  $\sqrt{5} \cdot \sqrt{6}$       22.  $\sqrt{3} \cdot \sqrt{8}$   
 23.  $7\sqrt{30} \cdot 2\sqrt{6}$       24.  $2\sqrt{3} \cdot 5\sqrt{27}$       25.  $\sqrt{40a^4}$   
 26.  $\sqrt{50m^3n^5}$       27.  $\sqrt{147x^6y^7}$       28.  $\sqrt{72x^3y^4z^5}$   
 29.  $\sqrt{\frac{2}{7}} \cdot \sqrt{\frac{7}{3}}$       30.  $\sqrt{\frac{3}{5}} \cdot \sqrt{\frac{6}{4}}$       31.  $\sqrt{\frac{t}{8}}$   
 32.  $\sqrt{\frac{27}{p^2}}$       33.  $\sqrt{\frac{5c^5}{4d^5}}$       34.  $\frac{\sqrt{9x^5y}}{\sqrt{12x^2y^6}}$   
 35.  $\frac{18}{6 - \sqrt{2}}$       36.  $\frac{3\sqrt{3}}{-2 + \sqrt{6}}$       37.  $\frac{10}{\sqrt{7} + \sqrt{2}}$   
 38.  $\frac{2}{\sqrt{3} + \sqrt{6}}$       39.  $\frac{4}{4 - 3\sqrt{3}}$       40.  $\frac{3\sqrt{7}}{5\sqrt{3} + 3\sqrt{5}}$

**INVESTIGATION** For Exercises 41–43, use the following information.

Police officers can use the formula  $s = \sqrt{30fd}$  to determine the speed  $s$  that a car was traveling in miles per hour by measuring the distance  $d$  in feet of its skid marks. In this formula,  $f$  is the coefficient of friction for the type and condition of the road.

41. Write a simplified formula for the speed if  $f = 0.6$  for a wet asphalt road.  
 42. What is a simplified formula for the speed if  $f = 0.8$  for a dry asphalt road?  
 43. An officer measures skid marks that are 110 feet long. Determine the speed of the car for both wet road conditions and for dry road conditions. Write in both simplified radical form and as a decimal approximation.  
 44. **GEOMETRY** A rectangle has a width of  $3\sqrt{5}$  centimeters and a length of  $4\sqrt{10}$  centimeters. Find the area of the rectangle. Write as a simplified radical expression.



**Real-World Career**

**Insurance Investigator**  
Insurance investigators decide whether claims are covered by the customer's policy, and investigate the circumstances of a claim.

**Math Online**

For more information, go to [algebra1.com](http://algebra1.com).

- 45. GEOMETRY** The formula for the area  $A$  of a square with side length  $s$  is  $A = s^2$ . Solve this equation for  $s$ , and find the side length of a square having an area of 72 square inches. Write as a simplified radical expression.

**PHYSICS** For Exercises 46 and 47, use the following information.

The formula for the kinetic energy of a moving object is  $E = \frac{1}{2}mv^2$ , where  $E$  is the kinetic energy in joules,  $m$  is the mass in kilograms, and  $v$  is the velocity in meters per second.

- 46.** Solve the equation for  $v$ .
- 47.** Find the velocity of an object whose mass is 0.6 kilogram and whose kinetic energy is 54 joules. Write as a simplified radical expression.
- 48. GEOMETRY** A rectangle has a length of  $\sqrt{\frac{a}{8}}$  meters and a width of  $\sqrt{\frac{a}{2}}$  meters. What is the area of the rectangle?
- 49. SPACE EXPLORATION** Refer to the application at the beginning of the lesson. Find the escape velocity for the Moon in kilometers per second if  $G = \frac{6.7 \times 10^{-20} \text{ km}}{\text{s}^2 \text{ kg}}$ ,  $M = 7.4 \times 10^{22} \text{ kg}$ , and  $R = 1.7 \times 10^3 \text{ km}$ . Use a calculator and write your answer as a decimal approximation. How does this compare to the escape velocity for Earth?

- 50. GEOMETRY** Hero's Formula can be used to calculate the area  $A$  of a triangle given the three side lengths  $a$ ,  $b$ , and  $c$ . Determine the area of a triangle if the side lengths of a triangle are 13, 10, and 7 feet.

$$A = \sqrt{s(s-a)(s-b)(s-c)}, \text{ where } s = \frac{1}{2}(a+b+c)$$

- 51. QUADRATIC FORMULA** Determine the next step in the derivation of the Quadratic Formula.

**Step 1**  $x^2 + \frac{b}{a}x + \frac{c}{a} = 0$

**Step 2**  $x^2 + \frac{b}{a}x = -\frac{c}{a}$

- 52. QUADRATIC FORMULA** Four steps in the derivation of the Quadratic Formula are shown below. Determine the correct order of the steps.

1  $x + \frac{b}{2a} = \pm \sqrt{\frac{b^2 - 4ac}{4a^2}}$

2  $x + \frac{b}{2a} = \pm \frac{\sqrt{b^2 - 4ac}}{2a}$

3  $\left| x + \frac{b}{2a} \right| = \sqrt{\frac{b^2 - 4ac}{4a^2}}$

4  $x^2 + \frac{b}{a}x = -\frac{c}{a}$

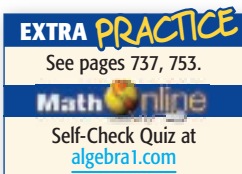

**H.O.T. Problems**

- 53. REASONING** Kary takes any number, subtracts 4, multiplies by 4, takes the square root, and takes the reciprocal to get  $\frac{1}{2}$ . What number did she start with? Write a formula to describe the process.
- 54. OPEN ENDED** Give an example of a binomial in the form  $a\sqrt{b} + c\sqrt{d}$  and its conjugate. Then find their product.

55. **FIND THE ERROR** Ben is solving  $(3x - 2)^2 = (2x + 6)^2$ . He found that  $x = -4$ . Is this solution correct? Explain.

56. **CHALLENGE** Solve the equation  $|y^3| = \frac{1}{3\sqrt{3}}$  for  $y$ .

57. **Writing in Math** Use the information about space exploration on page 580 to explain how radical expressions can be used in space exploration. Include an explanation of how you could determine the escape velocity of a planet and why you would need this information before you landed on it.

### STANDARDIZED TEST PRACTICE

58. **REVIEW** If the cube has a surface area of  $96a^2$ , what is its volume?

- A  $32a^3$
- B  $48a^3$
- C  $64a^3$
- D  $96a^3$

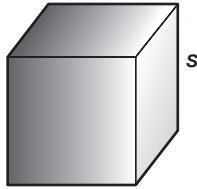

Formula for surface area of a cube =  $6s^2$

59. The perimeter  $P$  of a square can be found using the formula  $\frac{1}{4}P = \sqrt{A}$ , where  $A$  is the area of the square. What is the perimeter of a square with an area of 81 square centimeters?

- F 108 cm
- G 72 cm
- H 54 cm
- J 36 cm

### Spiral Review

Find the next three terms in each geometric sequence. (Lesson 9-7)

60. 2, 6, 18, 54

61. 1, -2, 4, -8

62. 384, 192, 96, 48

63.  $\frac{1}{9}, \frac{2}{3}, 4, 24$

64.  $3, \frac{3}{4}, \frac{3}{16}, \frac{3}{64}$

65. 50, 10, 2, 0.4

66. **BIOLOGY** A certain type of bacteria, if left alone, doubles its number every 2 hours. If there are 1000 bacteria at a certain point in time, how many bacteria will there be 24 hours later? (Lesson 9-6)

67. **PHYSICS** According to Newton's Law of Cooling, the difference between the temperature of an object and its surroundings decreases exponentially in time. Suppose a cup of coffee is  $95^\circ\text{C}$  and it is in a room that is  $20^\circ\text{C}$ . The cooling of the coffee can be modeled by the equation  $y = 75(0.875)^t$ , where  $y$  is the temperature difference and  $t$  is the time in minutes. Find the temperature of the coffee after 15 minutes. (Lesson 9-6)

Factor each trinomial, if possible. If the trinomial cannot be factored using integers, write *prime*. (Lesson 8-4)

68.  $6x^2 + 7x - 5$

69.  $35x^2 - 43x + 12$

70.  $5x^2 + 3x + 31$

### GET READY for the Next Lesson

**PREREQUISITE SKILL** Find each product. (Lesson 7-6)

71.  $(x - 3)(x + 2)$

72.  $(a + 2)(a + 5)$

73.  $(2t + 1)(t - 6)$

74.  $(4x - 3)(x + 1)$

75.  $(5x + 3y)(3x - y)$

76.  $(3a - 2b)(4a + 7b)$

# Graphing Calculator Lab Fractional Exponents

You have studied the properties of exponents that are whole numbers. You can use a calculator to explore the meaning of fractional exponents.

## ACTIVITY

**Step 1** Evaluate  $9^{\frac{1}{2}}$  and  $\sqrt{9}$ .

**KEYSTROKES:** 9  $\wedge$  ( 1  $\div$  2 ) **ENTER** 3

**KEYSTROKES:** **2nd** [ $\sqrt{\quad}$ ] 9 **ENTER** 3

Record the results in a table like the one at the right.

**Step 2** Use calculator to evaluate each expression. Record each result in your table. To find a root other than a square root, choose the  $\sqrt[n]{\quad}$  function from the **MATH** menu.

Expression	Value	Expression	Value
$9^{\frac{1}{2}}$	3	$\sqrt{9}$	3
$16^{\frac{1}{2}}$		$\sqrt{16}$	
$8^{\frac{1}{3}}$		$\sqrt[3]{8}$	
$27^{\frac{1}{3}}$		$\sqrt[3]{27}$	
$8^{\frac{2}{3}}$		$\sqrt[3]{8^2}$	
$16^{\frac{3}{4}}$		$\sqrt[4]{8^3}$	

**1A.** Study the table. What do you observe about the value of an expression of the form  $a^{\frac{1}{n}}$ ?

**1B.** What do you observe about the value of an expression of the form  $a^{\frac{m}{n}}$ ?

## ANALYZE THE RESULTS

- Recall the Power of a Power Property. For any number  $a$  and all integers  $m$  and  $n$ ,  $(a^m)^n = a^{m \cdot n}$ . Assume that fractional exponents behave as whole number exponents and find the value of  $(b^{\frac{1}{2}})^2$ .

$$\begin{aligned} \left(b^{\frac{1}{2}}\right)^2 &= b^{\frac{1}{2} \cdot 2} && \text{Power of a Power Property} \\ &= b^1 \text{ or } b && \text{Simplify.} \end{aligned}$$

Thus,  $b^{\frac{1}{2}}$  is a number whose square equals  $b$ . So it makes sense to define  $b^{\frac{1}{2}} = \sqrt{b}$ . Use a similar process to define  $b^{\frac{1}{n}}$ .

- Define  $b^{\frac{m}{n}}$ . Justify your answer.

Write each expression as a power of  $x$ .

3.  $\frac{\sqrt{x}}{(\sqrt[4]{x})(x)}$

4.  $\frac{(x)(\sqrt[3]{x})}{(\sqrt{x})(\sqrt[5]{x})}$

Write each root as an expression using a fractional exponent. Then evaluate the expression.

5.  $\sqrt{49}$

6.  $\sqrt[4]{81}$

7.  $\sqrt{4^3}$

8.  $\sqrt[3]{125^2}$



# Operations with Radical Expressions

## Main Ideas

- Add and subtract radical expressions.
- Multiply radical expressions.

### GET READY for the Lesson

The formula  $d = \sqrt{\frac{3h}{2}}$  represents the distance  $d$  in miles that a person  $h$  feet high can see. To determine how much farther a person can see from atop the Sears Tower than from atop the Empire State Building, we can substitute the heights of both buildings into the equation.

### World's Tall Structures

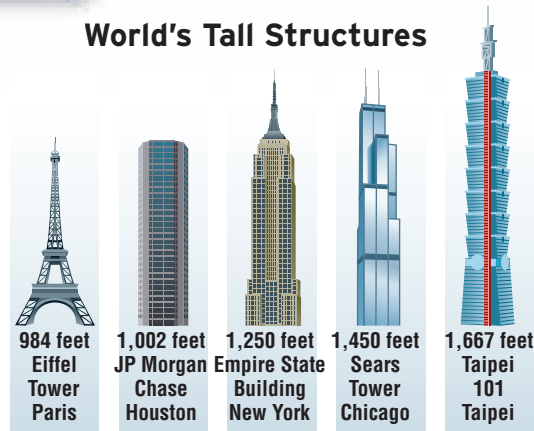

**Add and Subtract Radical Expressions** Radical expressions in which the radicands are alike can be added or subtracted in the same way that like monomials are added or subtracted.

#### Monomials

$$2x + 7x = (2 + 7)x \\ = 9x$$

$$15y - 3y = (15 - 3)y \\ = 12y$$

#### Radical Expressions

$$2\sqrt{11} + 7\sqrt{11} = (2 + 7)\sqrt{11} \\ = 9\sqrt{11}$$

$$15\sqrt{2} - 3\sqrt{2} = (15 - 3)\sqrt{2} \\ = 12\sqrt{2}$$

### EXAMPLE Expressions with Like Radicands

1 Simplify each expression.

a.  $4\sqrt{3} + 6\sqrt{3} - 5\sqrt{3}$

$$4\sqrt{3} + 6\sqrt{3} - 5\sqrt{3} = (4 + 6 - 5)\sqrt{3} \quad \text{Distributive Property} \\ = 5\sqrt{3} \quad \text{Simplify.}$$

b.  $12\sqrt{5} + 3\sqrt{7} + 6\sqrt{7} - 8\sqrt{5}$

$$12\sqrt{5} + 3\sqrt{7} + 6\sqrt{7} - 8\sqrt{5} = 12\sqrt{5} - 8\sqrt{5} + 3\sqrt{7} + 6\sqrt{7} \\ = (12 - 8)\sqrt{5} + (3 + 6)\sqrt{7} \quad \text{Distributive Property} \\ = 4\sqrt{5} + 9\sqrt{7} \quad \text{Simplify.}$$

### CHECK Your Progress

1A.  $3\sqrt{2} - 5\sqrt{2} + \sqrt{2}$

1B.  $15\sqrt{11} - 14\sqrt{13} + 6\sqrt{13} - 11\sqrt{11}$

In Example 1b,  $4\sqrt{5} + 9\sqrt{7}$  cannot be simplified further because the radicands are different. There are no common factors, and each radicand is in simplest form. If the radicals in an expression are not in simplest form, simplify them first.

### EXAMPLE Expressions with Unlike Radicands

2 Simplify  $2\sqrt{20} + 3\sqrt{45} + \sqrt{180}$ .

$$\begin{aligned} 2\sqrt{20} + 3\sqrt{45} + \sqrt{180} &= 2\sqrt{2^2 \cdot 5} + 3\sqrt{3^2 \cdot 5} + \sqrt{6^2 \cdot 5} \\ &= 2(\sqrt{2^2} \cdot \sqrt{5}) + 3(\sqrt{3^2} \cdot \sqrt{5}) + \sqrt{6^2} \cdot \sqrt{5} \\ &= 2(2\sqrt{5}) + 3(3\sqrt{5}) + 6\sqrt{5} \\ &= 4\sqrt{5} + 9\sqrt{5} + 6\sqrt{5} \\ &= 19\sqrt{5} \end{aligned}$$

### CHECK Your Progress

Simplify.

2A.  $4\sqrt{54} + 2\sqrt{24} - \sqrt{150}$

2B.  $4\sqrt{12} - 6\sqrt{48} + 5\sqrt{24}$

**Multiply Radical Expressions** Multiplying two radical expressions with different radicands is similar to multiplying binomials.

### EXAMPLE Multiply Radical Expressions

3 **GEOMETRY** Find the area of the rectangle in simplest form.

To find the area of the rectangle, multiply the measures of the length and width.

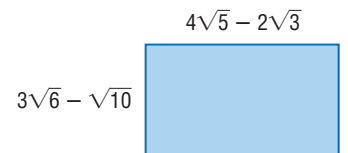

$$(4\sqrt{5} - 2\sqrt{3})(3\sqrt{6} - \sqrt{10})$$

First terms	Outer terms	Inner terms	Last terms
$(4\sqrt{5})(3\sqrt{6})$	$(4\sqrt{5})(-\sqrt{10})$	$(-2\sqrt{3})(3\sqrt{6})$	$(-2\sqrt{3})(-\sqrt{10})$
$= 12\sqrt{30} - 4\sqrt{50} - 6\sqrt{18} + 2\sqrt{30}$			
$= 12\sqrt{30} - 4\sqrt{5^2 \cdot 2} - 6\sqrt{3^2 \cdot 2} + 2\sqrt{30}$			
$= 12\sqrt{30} - 20\sqrt{2} - 18\sqrt{2} + 2\sqrt{30}$			
$= 14\sqrt{30} - 38\sqrt{2}$			

**Multiply.**

**Prime factorization**

**Simplify.**

**Combine like terms.**

### Study Tip

#### Look Back

To review the **FOIL method**, see Lesson 7-6.

### CHECK Your Progress

Find each product.

3A.  $(5\sqrt{5} - 4\sqrt{3})(6\sqrt{10} - 2\sqrt{6})$

3B.  $(6\sqrt{7} + 3\sqrt{2})(4\sqrt{10} - 5\sqrt{6})$

**Personal Tutor at** [algebra1.com](http://algebra1.com)

You can use a calculator to verify that a simplified radical expression is equivalent to the original expression. Consider Example 3. First, find a decimal approximation for the original expression.

**KEYSTROKES:** ( 4 2nd [√] 5 ) - 2 2nd [√] 3 ) ) ( 3 2nd [√] 6 ) - 2nd [√] 10 ) ) ENTER  
22.94104268

Next, find a decimal approximation for the simplified expression.

**KEYSTROKES:** 14 2nd [√] 30 ) - 38 2nd [√] 2 ) ) ENTER  
22.94104268

Since the approximations are equal, the expressions are equivalent.

## CHECK Your Understanding

**Examples 1, 2**  
(pp. 536–537)

**Simplify.**

- $4\sqrt{3} + 7\sqrt{3}$
- $2\sqrt{6} - 7\sqrt{6}$
- $5\sqrt{5} - 3\sqrt{20}$
- $2\sqrt{3} + \sqrt{12}$
- $3\sqrt{5} + 5\sqrt{6} + 3\sqrt{20}$
- $8\sqrt{3} + \sqrt{3} + \sqrt{9}$

**Example 3**  
(p. 537)

**Find each product.**

- $\sqrt{2}(\sqrt{8} + 4\sqrt{3})$
- $(4 + \sqrt{5})(3 + \sqrt{5})$

- GEOMETRY** Find the perimeter and the area of the square.

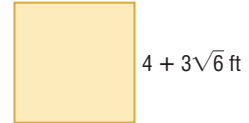

- ELECTRICITY** The voltage  $V$  required for a circuit is given by  $V = \sqrt{PR}$ , where  $P$  is the power in watts and  $R$  is the resistance in ohms. How many more volts are needed to light a 100-watt bulb than a 75-watt bulb if the resistance for both is 110 ohms?

## Exercises

HOMEWORK HELP	
For Exercises	See Examples
11–18	1
19–22	2
23–33	3

**Simplify.**

- $8\sqrt{5} + 3\sqrt{5}$
- $3\sqrt{6} + 10\sqrt{6}$
- $2\sqrt{15} - 6\sqrt{15} - 3\sqrt{15}$
- $5\sqrt{19} + 6\sqrt{19} - 11\sqrt{19}$
- $16\sqrt{x} + 2\sqrt{x}$
- $3\sqrt{5b} - 4\sqrt{5b} + 11\sqrt{5b}$
- $8\sqrt{3} - 2\sqrt{2} + 3\sqrt{2} + 5\sqrt{3}$
- $4\sqrt{6} + \sqrt{17} - 6\sqrt{2} + 4\sqrt{17}$
- $\sqrt{18} + \sqrt{12} + \sqrt{8}$
- $\sqrt{6} + 2\sqrt{3} + \sqrt{12}$
- $3\sqrt{7} - 2\sqrt{28}$
- $2\sqrt{50} - 3\sqrt{32}$

**Find each product.**

- $\sqrt{6}(\sqrt{3} + 5\sqrt{2})$
- $\sqrt{5}(2\sqrt{10} + 3\sqrt{2})$
- $(3 + \sqrt{5})(3 - \sqrt{5})$
- $(7 - \sqrt{10})^2$
- $(\sqrt{6} + \sqrt{8})(\sqrt{24} + \sqrt{2})$
- $(\sqrt{5} - \sqrt{2})(\sqrt{14} + \sqrt{35})$
- $(2\sqrt{10} + 3\sqrt{15})(3\sqrt{3} - 2\sqrt{2})$
- $(5\sqrt{2} + 3\sqrt{5})(2\sqrt{10} - 3)$



**Real-World Link**

The Sears Tower was the tallest building in the world from 1974 to 1996. You can see four states from its roof: Michigan, Indiana, Illinois, and Wisconsin.

Source: the-skydeck.com

**EXTRA PRACTICE**  
See pages 737, 753.

**Math online**  
Self-Check Quiz at [algebra1.com](http://algebra1.com)

**H.O.T. Problems**

- 31. GEOMETRY** Find the perimeter and area of a rectangle with a length of  $8\sqrt{7} + 4\sqrt{5}$  inches and a width of  $2\sqrt{7} - 3\sqrt{5}$  inches.
- 32. GEOMETRY** The perimeter of a rectangle is  $2\sqrt{3} + 4\sqrt{11} + 6$  centimeters, and its length is  $2\sqrt{11} + 1$  centimeters. Find the width.
- 33. GEOMETRY** The area  $A$  of a rhombus can be found using the formula  $A = \frac{1}{2}d_1d_2$ , where  $d_1$  and  $d_2$  are the lengths of the diagonals of the rhombus. What is the area of the rhombus at the right?

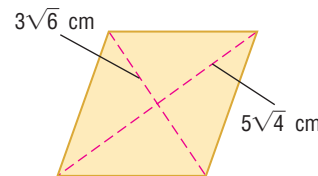

**Simplify.**

**34.**  $\sqrt{2} + \sqrt{\frac{1}{2}}$

**35.**  $\sqrt{10} - \sqrt{\frac{2}{5}}$

**36.**  $3\sqrt{3} - \sqrt{45} + 3\sqrt{\frac{1}{3}}$

**37.**  $6\sqrt{\frac{7}{4}} + 3\sqrt{28} - 10\sqrt{\frac{1}{7}}$

**DISTANCE** For Exercises 38 and 39, refer to the application at the beginning of the lesson.

- 38.** How much farther can a person see from atop the Sears Tower than from atop the Empire State Building? Write as a simplified radical expression and as a decimal approximation.
- 39.** A person atop the Empire State Building can see approximately 4.57 miles farther than a person atop the Texas Commerce Tower in Houston. Explain how you could find the height of the Texas Commerce Tower.

**ENGINEERING** For Exercises 40 and 41, use the following information.

The equation  $r = \sqrt{\frac{F}{5\pi}}$  relates the radius  $r$  of a drainpipe, in inches, to the flow rate  $F$  of water passing through it, in gallons per minute.

- 40.** Find the radius of a pipe that can carry 500 gallons of water per minute. Write as a simplified radical expression, and use a calculator to find the decimal approximation. Round to the nearest whole number.
- 41.** An engineer determines that a drainpipe must be able to carry 1000 gallons of water per minute and instructs the builder to use an 8-inch radius pipe. Can the builder use two 4-inch radius pipes instead? Justify your answer.

**MOTION** For Exercises 42 and 43, use the following information.

The velocity of an object dropped from a certain height can be found using the formula  $v = \sqrt{2gd}$ , where  $v$  is the velocity in feet per second,  $g$  is the acceleration due to gravity, and  $d$  is the distance the object drops, in feet.

- 42.** Find the speed of an object that has fallen 25 feet and the speed of an object that has fallen 100 feet. Use 32 feet per second squared for  $g$ . Write as a simplified radical expression.
- 43.** When you increased the distance by 4 times, what happened to the velocity? Explain.
- 44. CHALLENGE** Determine whether the following statement is *true* or *false*. Provide an example or counterexample to support your answer.

$$x + y > \sqrt{x^2 + y^2} \text{ when } x > 0 \text{ and } y > 0$$



45. **OPEN ENDED** Choose values for  $x$  and  $y$ . Then find  $(\sqrt{x} + \sqrt{y})^2$ .
46. **Which One Doesn't Belong?** Three of these expressions are equivalent. Which one is not?
- $6\sqrt{6} - 24\sqrt{2} + 6\sqrt{6} - 5\sqrt{2}$

$12\sqrt{6} - 29\sqrt{2}$
- $29\sqrt{2} - 12\sqrt{6}$

$3\sqrt{24} - 6\sqrt{32} + 2\sqrt{54} - \sqrt{50}$
47. **CHALLENGE** Under what conditions is  $(\sqrt{a+b})^2 = (\sqrt{a})^2 + (\sqrt{b})^2$  true?
48. *Writing in Math* Use the information about the world's tall structures on page 536 to explain how you can use radicals to determine how far a person can see. Include an explanation of how this information could help determine how far apart lifeguard towers should be on a beach.

### STANDARDIZED TEST PRACTICE

49.  $\sqrt{3}(4 + \sqrt{12})^2 =$
- A  $4\sqrt{3} + 6$   
 B  $28\sqrt{3}$   
 C  $28 + 16\sqrt{3}$   
 D  $48 + 28\sqrt{3}$

50. **REVIEW** Which expression is equivalent to  $3^8 \cdot 3^2 \cdot 3^4$ ?
- F  $3^{14}$                       H  $27^{14}$   
 G  $3^{64}$                       J  $27^{64}$

### Spiral Review

Simplify. (Lesson 10-1)

51.  $\sqrt{40}$   
 54.  $\frac{\sqrt{50}}{\sqrt{8}}$

52.  $\sqrt{128}$   
 55.  $\sqrt{\frac{225c^4d}{18c^2}}$

53.  $-\sqrt{196x^2y^3}$   
 56.  $\sqrt{\frac{63a}{128a^3b^2}}$

Find the  $n$ th term of each geometric sequence. (Lesson 9-7)

57.  $a_1 = 4, n = 6, r = 4$

58.  $a_1 = -7, n = 4, r = 9$

59.  $a_1 = 2, n = 8, r = -0.8$

Solve each equation by factoring. Check your solutions. (Lesson 8-5)

60.  $81 = 49y^2$

61.  $q^2 - \frac{36}{121} = 0$

62.  $48n^3 - 75n = 0$

63.  $5x^3 - 80x = 240 - 15x^2$

64. **RUNNING** Tyler runs 17 miles each Saturday. It takes him about 2 hours to run this distance. At this rate, how far could he run in 3 hours and 30 minutes? (Lesson 2-6)

### GET READY for the Next Lesson

**PREREQUISITE SKILL** Find each product. (Lesson 7-7)

65.  $(x - 2)^2$

66.  $(x + 5)^2$

67.  $(x + 6)^2$

68.  $(3x - 1)^2$

69.  $(2x - 3)^2$

70.  $(4x + 7)^2$

**Main Ideas**

- Solve radical equations.
- Solve radical equations with extraneous solutions.

**New Vocabulary**

radical equation  
extraneous solution

**GET READY for the Lesson**

Skydivers fall 1050 to 1480 feet every 5 seconds, reaching speeds of 120 to 150 miles per hour at *terminal velocity*. It is the highest speed they can reach and occurs when the air resistance equals the force of gravity. With no air resistance, the time  $t$  in seconds that it takes an object to fall  $h$  feet can be determined by the equation

$t = \frac{\sqrt{h}}{4}$ . How would you find the value of  $h$  if you are given the value of  $t$ ?



**Radical Equations** Equations like  $t = \frac{\sqrt{h}}{4}$  that contain radicals with variables in the radicand are called **radical equations**. To solve these equations, first isolate the radical on one side of the equation. Then square each side of the equation to eliminate the radical.

**Real-World EXAMPLE****Variable in Radical**

**FREE-FALL HEIGHT** Two objects are dropped simultaneously. The first object reaches the ground in 2.5 seconds, and the second object reaches the ground 1.5 seconds later. From what heights were the two objects dropped?

First Object

$$t = \frac{\sqrt{h}}{4} \quad \text{Original equation}$$

$$2.5 = \frac{\sqrt{h}}{4} \quad \text{Replace } t \text{ with } 2.5.$$

$$10 = \sqrt{h} \quad \text{Multiply each side by } 4.$$

$$10^2 = (\sqrt{h})^2 \quad \text{Square each side.}$$

$$100 = h \quad \text{Simplify.}$$

Second Object

$$t = \frac{\sqrt{h}}{4} \quad \text{Original equation}$$

$$4 = \frac{\sqrt{h}}{4} \quad \text{Replace } t \text{ with } 4.$$

$$16 = \sqrt{h} \quad \text{Multiply each side by } 4.$$

$$16^2 = (\sqrt{h})^2 \quad \text{Square each side.}$$

$$256 = h \quad \text{Simplify.}$$

Check the results by substituting 100 and 256 for  $h$  in the original equation.

(continued on the next page)



$$\begin{aligned} \text{CHECK } t &= \frac{\sqrt{h}}{4} && \text{Original equation} \\ &\stackrel{?}{=} \frac{\sqrt{100}}{4} && h = 100 \\ &\stackrel{?}{=} \frac{10}{4} && \sqrt{100} = 10 \\ &= 2.5 && \text{Simplify.} \end{aligned}$$

The first object was dropped from 100 feet.

$$\begin{aligned} \text{CHECK } t &= \frac{\sqrt{h}}{4} && \text{Original equation} \\ &= \frac{\sqrt{256}}{4} && h = 256 \\ &= \frac{16}{4} && \sqrt{256} = 16 \\ &= 4 && \text{Simplify.} \end{aligned}$$

The second object was dropped from 256 feet.

### CHECK Your Progress

1. **DIVING** At the swim meet, Brandon dived off two platforms at different heights. On the first dive, it took him 0.78 second to reach the water. On the next dive, it took Brandon 1.43 seconds to reach the water. How much higher is the second platform than the first?

### EXAMPLE Radical Equation with an Expression

2 Solve  $\sqrt{x+1} + 7 = 10$ .

$$\sqrt{x+1} + 7 = 10 \quad \text{Original equation}$$

$$\sqrt{x+1} = 3 \quad \text{Subtract 7 from each side to isolate the radical expression.}$$

$$(\sqrt{x+1})^2 = 3^2 \quad \text{Square each side.}$$

$$x+1 = 9 \quad (\sqrt{x+1})^2 = x+1$$

$$x = 8 \quad \text{Subtract 1 from each side. Check this result.}$$

### CHECK Your Progress

Solve each equation. Check your solution.

2A.  $\sqrt{x-3} - 2 = 4$

2B.  $4 + \sqrt{x+1} = 14$

**Extraneous Solutions** Squaring each side of an equation sometimes produces extraneous solutions. An **extraneous solution** is a solution derived from an equation that is not a solution of the original equation. Therefore, you must check all solutions in the original equation when you solve radical equations.

### EXAMPLE Variable on Each Side

5 Solve  $\sqrt{x+2} = x-4$ .

$$\sqrt{x+2} = x-4 \quad \text{Original equation}$$

$$(\sqrt{x+2})^2 = (x-4)^2 \quad \text{Square each side.}$$

$$x+2 = x^2 - 8x + 16 \quad \text{Simplify.}$$

$$0 = x^2 - 9x + 14 \quad \text{Subtract } x \text{ and 2 from each side.}$$

$$0 = (x-7)(x-2) \quad \text{Factor.}$$

$$x-7 = 0 \quad \text{or} \quad x-2 = 0 \quad \text{Zero Product Property}$$

$$x = 7 \qquad x = 2 \quad \text{Solve.}$$

### Review Vocabulary

#### Zero Product Property

For all numbers  $a$  and  $b$ , if  $ab = 0$ , then  $a = 0$ ,  $b = 0$ , or both  $a$  and  $b$  equal 0. (Lesson 9-2)

**CHECK**  $\sqrt{x+2} = x - 4$  Original equation

$\sqrt{7+2} \stackrel{?}{=} 7 - 4$   $x = 7$

$\sqrt{9} \stackrel{?}{=} 3$  Simplify.

$3 = 3$  ✓ True

$\sqrt{x+2} = x - 4$  Original equation

$\sqrt{2+2} \stackrel{?}{=} 2 - 4$   $x = 2$

$\sqrt{4} \stackrel{?}{=} -2$  Simplify.

$2 \neq -2$  ✗ False

Since 2 does not satisfy the original equation, 7 is the only solution.

### CHECK Your Progress

Solve each equation. Check your solution.

**3A.**  $\sqrt{x+5} = x + 3$

**3B.**  $x - 3 = \sqrt{x - 1}$

 Online Personal Tutor at [algebra1.com](http://algebra1.com)

## GRAPHING CALCULATOR LAB

### Solving Radical Equations

You can use a graphing calculator to solve radical equations such as  $\sqrt{3x - 5} = x - 5$ . Clear the Y= list. Enter the left side of the equation as  $Y1 = \sqrt{3x - 5}$ . Enter the right side of the equation as  $Y2 = x - 5$ . Press .

#### THINK AND DISCUSS

1. Sketch what is shown on the screen.
2. Use the intersect feature on the CALC menu, to find the point of intersection.
3. Solve the radical equation algebraically. How does your solution compare to the solution from the graph?

### CHECK Your Understanding

**Example 1**  
(pp. 541–542)

Solve each equation. Check your solution.

1.  $\sqrt{x} = 5$

2.  $\sqrt{2b} = -8$

3.  $\sqrt{7x} = 7$

4. **GEOMETRY** The surface area of a basketball is  $x$  square inches. What is the radius of the basketball if the formula for the surface area of a sphere is  $SA = 4\pi r^2$ ?

**Examples 2, 3**  
(pp. 542–543)

Solve each equation. Check your solution.

5.  $\sqrt{8s + 1} = 5$

6.  $\sqrt{7x + 18} = 9$

7.  $\sqrt{5x + 1} + 2 = 6$

8.  $\sqrt{3x - 5} = x - 5$

9.  $4 + \sqrt{x - 2} = x$

10.  $\sqrt{2x + 3} = x$



Extra Examples at [algebra1.com](http://algebra1.com)

# Exercises

HOMEWORK HELP	
For Exercises	See Examples
11–15, 29–30	1
16–22	2
23–28	3

Solve each equation. Check your solution.

- |                                |                             |                              |
|--------------------------------|-----------------------------|------------------------------|
| 11. $\sqrt{-3a} = 6$           | 12. $\sqrt{a} = 10$         | 13. $\sqrt{-k} = 4$          |
| 14. $5\sqrt{2} = \sqrt{x}$     | 15. $3\sqrt{7} = \sqrt{-y}$ | 16. $3\sqrt{4a} - 2 = 10$    |
| 17. $3 + 5\sqrt{n} = 18$       | 18. $\sqrt{x+3} = -5$       | 19. $\sqrt{x-5} = 2\sqrt{6}$ |
| 20. $\sqrt{3x+12} = 3\sqrt{3}$ | 21. $\sqrt{2c-4} = 8$       | 22. $\sqrt{4b+1} - 3 = 0$    |
| 23. $x = \sqrt{6-x}$           | 24. $x = \sqrt{x+20}$       | 25. $\sqrt{5x-6} = x$        |
| 26. $\sqrt{28-3x} = x$         | 27. $\sqrt{x+1} = x-1$      | 28. $\sqrt{1-2b} = 1+b$      |

**AVIATION** For Exercises 29 and 30, use the following information.

The formula  $L = \sqrt{kP}$  represents the relationship between a plane's length  $L$  and the pounds  $P$  its wings can lift, where  $k$  is a constant of proportionality calculated for a plane.

29. The length of the Douglas D-558-II, called the Skyrocket, was approximately 42 feet, and its constant of proportionality was  $k = 0.1669$ . Calculate the maximum takeoff weight of the Skyrocket.
30. A Boeing 747 is 232 feet long and has a takeoff weight of 870,000 pounds. Determine the value of  $k$  for this plane.
31. The square root of the sum of a number and 7 is 8. Find the number.
32. The square root of the quotient of a number and 6 is 9. Find the number.

Solve each equation. Check your solution.

- |                                    |                                    |
|------------------------------------|------------------------------------|
| 33. $\sqrt{3r-5} + 7 = 3$          | 34. $\sqrt{x^2 + 9x + 14} = x + 4$ |
| 35. $5\sqrt{\frac{4t}{3}} - 2 = 0$ | 36. $\sqrt{\frac{4x}{5}} - 9 = 3$  |
| 37. $4 + \sqrt{m-2} = m$           | 38. $\sqrt{3d-8} = d-2$            |
| 39. $x + \sqrt{6-x} = 4$           | 40. $\sqrt{6-3x} = x+16$           |
| 41. $\sqrt{2r^2-121} = r$          | 42. $\sqrt{5p^2-7} = 2p$           |

**GEOMETRY** For Exercises 43–46, use the figure.

The area  $A$  of a circle is equal to  $\pi r^2$ , where  $r$  is the radius of the circle.

43. Write an equation for  $r$  in terms of  $A$ .
44. The area of the larger circle is  $96\pi$  square meters. Find the radius.
45. The area of the smaller circle is  $48\pi$  square meters. Find the radius.
46. If the area of a circle is doubled, what is the change in the radius?

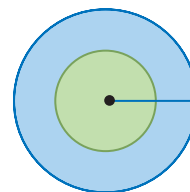

**OCEANS** For Exercises 47–49, use the following information.

Tsunamis, or large waves, are generated by undersea earthquakes. The speed of the tsunami in meters per second is  $s = 3.1\sqrt{d}$ , where  $d$  is the depth of the ocean in meters.

47. Find the speed of the tsunami if the depth of the water is 10 meters.
48. Find the depth of the water if a tsunami's speed is 240 meters per second.
49. A tsunami may begin as a 2-foot high wave traveling 500 miles per hour. It can approach a coastline as a 50-foot wave. How much speed does the wave lose if it travels from a depth of 10,000 meters to a depth of 20 meters?



## Real-World Link

Piloted by A. Scott Crossfield on November 20, 1953, the Douglas D-558-2 Skyrocket became the first aircraft to fly faster than Mach 2, twice the speed of sound.

Source: National Air and Space Museum

## EXTRA PRACTICE

See pages 737, 753.

Math online

Self-Check Quiz at [algebra1.com](http://algebra1.com)

50. State whether the following equation is *sometimes*, *always*, or *never* true.

$$\sqrt{(x - 5)^2} = x - 5$$



 **Real-World Link**

The Foucault Pendulum appears to change its path during the day, but it moves in a straight line. The path under the pendulum changes because Earth is rotating beneath it.

Source: California Academy of Sciences

**PHYSICAL SCIENCE** For Exercises 51–53, use the following information.

The formula  $P = 2\pi\sqrt{\frac{\ell}{32}}$  gives the period of a pendulum of length  $\ell$  feet. The period  $P$  is the number of seconds it takes for the pendulum to swing back and forth once.

51. Suppose we want a pendulum to complete three periods in 2 seconds. How long should the pendulum be?
52. Two clocks have pendulums of different lengths. The first clock requires 1 second for its pendulum to complete one period. The second clock requires 2 seconds for its pendulum to complete one period. How much longer is one pendulum than the other?
53. Repeat Exercise 52 if the pendulum periods are  $t$  and  $2t$  seconds.

**BROADCASTING** For Exercises 54–56, use the following information.

Sports broadcasts often include sound collection from the field of play. The temperature affects the speed of sound near Earth's surface. The speed  $V$  when the surface temperature  $t$  degrees Celsius can be found using the equation  $V = 20\sqrt{t + 273}$ .

54. Find the temperature at a baseball game if the speed of sound is 346 meters per second.
55. The speed of sound at Earth's surface is often given as 340 meters per second, but that is only accurate at a certain temperature. On what temperature is this figure based?
56. For what speeds is the surface temperature below  $0^\circ\text{C}$ ?



**Graphing Calculator**

Use a graphing calculator to solve each radical equation. Round to the nearest hundredth.

57.  $3 + \sqrt{2x} = 7$                       58.  $\sqrt{3x - 8} = 5$                       59.  $\sqrt{x + 6} - 4 = x$
60.  $\sqrt{4x + 5} = x - 7$                       61.  $x + \sqrt{7 - x} = 4$                       62.  $\sqrt{3x - 9} = 2x + 6$

**H.O.T. Problems**

63. **REASONING** Explain why it is necessary to check for extraneous solutions in radical equations.
64. **OPEN ENDED** Give an example of a radical equation. Then solve the equation for the variable.
65. **FIND THE ERROR** Alex and Victor are solving  $-\sqrt{x - 5} = -2$ . Who is correct? Explain your reasoning.

Alex

$$\begin{aligned} -\sqrt{x - 5} &= -2 \\ (-\sqrt{x - 5})^2 &= (-2)^2 \\ x - 5 &= 4 \\ x &= 9 \end{aligned}$$

Victor

$$\begin{aligned} -\sqrt{x - 5} &= -2 \\ -(\sqrt{x - 5})^2 &= (-2)^2 \\ -(x - 5) &= 4 \\ -x + 5 &= 4 \\ x &= 1 \end{aligned}$$

66. **CHALLENGE** Solve  $\sqrt{h + 9} - \sqrt{h} = \sqrt{3}$ .

67. **Writing in Math** Use the information about skydiving on page 541 to explain how radical equations can be used to find free-fall times. Include the time it would take a skydiver to fall 10,000 feet if he falls 1200 feet every 5 seconds and also the time it would take using the equation  $t = \frac{\sqrt{h}}{4}$ , with an explanation of why the two methods find different times.

### STANDARDIZED TEST PRACTICE

68. What is the solution for this equation?

$$\sqrt{x+3} - 2 = 7$$

- A 22  
B 78  
C 36  
D 15

69. **REVIEW** Mr. and Mrs. Hataro are putting fresh sod onto their yard. The yard is 30 feet wide and 24 feet long, and the sod comes in pieces that are 12 inches wide and 24 inches long. If they decide to cover the entire yard in sod, about how many pieces of sod will they need?

- F 2.5                      H 360  
G 30                        J 720

### Spiral Review

**Simplify.** (Lessons 10-2 and 10-1)

70.  $5\sqrt{6} + 12\sqrt{6}$

71.  $\sqrt{12} + 6\sqrt{27}$

72.  $\sqrt{18} + 5\sqrt{2} - 3\sqrt{32}$

73.  $\sqrt{192}$

74.  $\sqrt{6} \cdot \sqrt{10}$

75.  $\frac{21}{\sqrt{10} + \sqrt{3}}$

**Find each product.** (Lesson 7-6)

76.  $(r + 3)(r - 4)$

77.  $(3z + 7)(2z + 10)$

78.  $(2p + 5)(3p^2 - 4p + 9)$

79. **PHYSICAL SCIENCE** A European-made hot tub is advertised to have a temperature of  $35^{\circ}\text{C}$  to  $40^{\circ}\text{C}$ , inclusive. What is the temperature range for the hot tub in degrees Fahrenheit? Use  $F = \frac{9}{5}C + 32$ . (Lesson 6-4)

**Write each equation in standard form.** (Lesson 4-5)

80.  $y = 2x + \frac{3}{7}$

81.  $y - 3 = -2(x - 6)$

82.  $y + 2 = 7.5(x - 3)$

83. **MUSIC** The table shows the number of country music radio stations in the United States. What was the percent of change in the number of stations from 2002 to 2004? (Lesson 2-7)

Year	Number of Stations
2002	2131
2004	2047

Source: M Street Corporation

### GET READY for the Next Lesson

**PREREQUISITE SKILL** Evaluate  $\sqrt{a^2 + b^2}$  for each value of  $a$  and  $b$ . (Lesson 1-2)

84.  $a = 3, b = 4$

85.  $a = 24, b = 7$

86.  $a = 5, b = 12$

87.  $a = 6, b = 8$

88.  $a = 1, b = 1$

89.  $a = 8, b = 12$

# Graphing Calculator Lab

## Graphs of Radical Equations

In order for a square root to be a real number, the radicand cannot be negative. When graphing a radical equation, determine when the radicand would be negative and exclude those values from the domain.

### ACTIVITY 1

Graph  $y = \sqrt{x}$ .

Enter the equation in the Y= list.

**KEYSTROKES:**  $\boxed{Y=}$   $\boxed{2nd}$   $\boxed{[\sqrt{\quad}]}$   $\boxed{X,T,\theta,n}$   $\boxed{\text{Graph}}$

**1A.** Examine the graph. What is the domain of the function  $y = \sqrt{x}$ ?

**1B.** What is the range of  $y = \sqrt{x}$ ?

### Concepts in Motion

Interactive Lab [algebra1.com](http://algebra1.com)

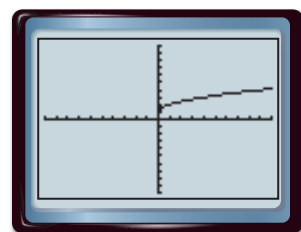

$[-10, 10]$  scl: 1 by  $[-10, 10]$  scl: 1

### ACTIVITY 2

Graph  $y = \sqrt{x + 4}$ .

Enter the equation in the Y= list.

**KEYSTROKES:**  $\boxed{Y=}$   $\boxed{2nd}$   $\boxed{[\sqrt{\quad}]}$   $\boxed{X,T,\theta,n}$   $\boxed{+}$   $\boxed{4}$   $\boxed{)}$   $\boxed{\text{Graph}}$

**2A.** What are the domain and range of  $y = \sqrt{x + 4}$ ?

**2B.** How does the graph of  $y = \sqrt{x + 4}$  compare to the graph of the parent function  $y = \sqrt{x}$ ?

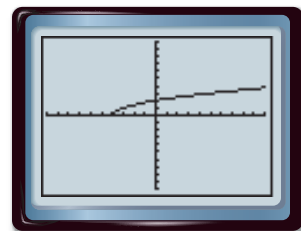

$[-10, 10]$  scl: 1 by  $[-10, 10]$  scl: 1

### ANALYZE THE RESULTS

Graph each equation and sketch the graph on your paper. State the domain of the graph. Then describe how the graph differs from the parent function  $y = \sqrt{x}$ .

1.  $y = \sqrt{x} + 1$
2.  $y = \sqrt{x} - 3$
3.  $y = \sqrt{x + 2}$
4.  $y = \sqrt{x - 5}$
5.  $y = \sqrt{-x}$
6.  $y = \sqrt{3x}$
7.  $y = -\sqrt{x}$
8.  $y = \sqrt{1 - x} + 6$
9.  $y = \sqrt{2x + 5} - 4$
10.  $y = \sqrt{|x| + 2}$
11.  $y = \sqrt{|x| - 3}$
12. Is the graph of  $x = y^2$  a function? Explain your reasoning.
13. Does the equation  $x^2 + y^2 = 1$  determine  $y$  as a function of  $x$ ? Explain.
14. Write a function whose graph is the graph of  $y = \sqrt{x}$  shifted 3 units up.



**Simplify.** (Lesson 10-1)

- $\sqrt{48}$
- $\sqrt{3} \cdot \sqrt{6}$
- $\frac{3}{2 + \sqrt{10}}$

4. **MULTIPLE CHOICE** If  $x = 81b^2$  and  $b > 0$ , then  $\sqrt{x} =$  (Lesson 10-1)

- A  $-9b$ .  
 B  $9b$ .  
 C  $3b\sqrt{27}$ .  
 D  $27b\sqrt{3}$ .

**FENCE** For Exercises 5-7, use the following information.

Hailey wants to put up a fence. She has a square backyard with an area of 160 square feet. The formula for the area  $A$  of a square with side length  $s$  is  $A = s^2$ . (Lesson 10-1)

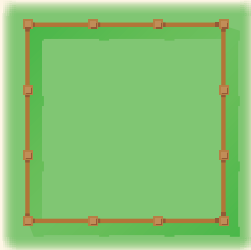

- Solve the equation for  $s$ .
- What is the side length of Hailey's backyard?
- What is the perimeter of Hailey's backyard?
- GEOMETRY** A rectangle has a length of  $\sqrt{\frac{a}{8}}$  meters and a width of  $\sqrt{\frac{a}{2}}$  meters. What is the area of the rectangle?

**Simplify.** (Lesson 10-2)

- $6\sqrt{5} + 3\sqrt{11} + 5\sqrt{5}$
- $2\sqrt{3} + 9\sqrt{12}$
- $(3 - \sqrt{6})^2$

12. **GEOMETRY** Find the area of a square with a side measure of  $2 + \sqrt{7}$  centimeters. (Lesson 10-2)

**SOUND** For Exercises 13 and 14, use the following information.

The speed of sound  $V$  in meters per second near Earth's surface is given by  $V = 20\sqrt{t + 273}$ , where  $t$  is the surface temperature in degrees Celsius. (Lesson 10-2)

- What is the speed of sound near Earth's surface at  $-1^\circ\text{C}$  and at  $6^\circ\text{C}$  in simplest form?
- How much faster is the speed of sound at  $6^\circ\text{C}$  than at  $-1^\circ\text{C}$ ?

**Solve each equation. Check your solution.**

(Lesson 10-3)

- $\sqrt{15 - x} = 4$
- $\sqrt{3x^2 - 32} = x$
- $\sqrt{2x - 1} = 2x - 7$

18. **MULTIPLE CHOICE** The surface area  $S$  of a cone can be found by using  $S = \pi r\sqrt{r^2 + h^2}$ , where  $r$  is the radius of the base and  $h$  is the height of the cone. Find the height of the cone. (Lesson 10-3)

- F 2.70 in.  
 G 11.03 in.  
 H 12.84 in.  
 J 13.30 in.

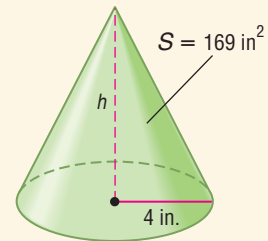

19. **PHYSICS** When an object is dropped from the top of a 250-foot tall building, the object will be  $h$  feet above the ground after  $t$  seconds, where  $\frac{\sqrt{250 - h}}{4} = t$ . How far above the ground will the object be after 1 second?

(Lesson 10-3)

20. **SKYDIVING** The approximate time  $t$  in seconds that it takes an object to fall a distance of  $d$  feet is given by  $t = \sqrt{\frac{d}{16}}$ . Suppose a parachutist falls 13 seconds before the parachute opens. How far does the parachutist fall during this time period? (Lesson 10-3)

**Main Ideas**

- Solve problems by using the Pythagorean Theorem.
- Determine whether a triangle is a right triangle.

**New Vocabulary**

hypotenuse  
legs  
Pythagorean triple  
converse

**Study Tip****Triangles**

Sides of a triangle are represented by lowercase letters  $a$ ,  $b$ , and  $c$ .

**GET READY for the Lesson**

The *Cyclone* roller coaster at New York's Coney Island is one of the most copied roller coasters in the world. Since it was built in 1927, seven copies of the coaster have been built. The first drop is 85 feet tall, and it descends at a  $60^\circ$  angle. The top speed is 60 miles per hour. You can use the Pythagorean Theorem to estimate the length of the first hill.

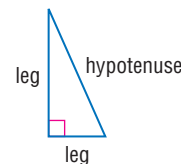

**The Pythagorean Theorem** In a right triangle, the side opposite the right angle is the **hypotenuse**. This side is always the longest side of a right triangle. The other two sides are the **legs**. To find the length of any side of a right triangle when the lengths of the other two are known, use a formula named for the Greek mathematician Pythagoras.

**KEY CONCEPT****The Pythagorean Theorem**

**Words** If  $a$  and  $b$  are the lengths of the legs of a right triangle and  $c$  is the length of the hypotenuse, then the square of the length of the hypotenuse is equal to the sum of the squares of the lengths of the legs.

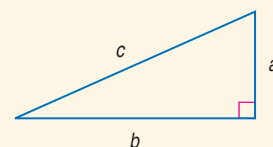

**Symbols**  $c^2 = a^2 + b^2$

**EXAMPLE Find the Length of the Hypotenuse**

- 1** Find the length of the hypotenuse of a right triangle if  $a = 8$  and  $b = 15$ .

$$c^2 = a^2 + b^2 \quad \text{Pythagorean Theorem}$$

$$c^2 = 8^2 + 15^2 \quad a = 8 \text{ and } b = 15$$

$$c^2 = 289 \quad \text{Simplify.}$$

$$c = \pm\sqrt{289} \quad \text{Take the square root of each side.}$$

$$c = \pm 17 \quad \text{Disregard } -17. \text{ Why?}$$

The length of the hypotenuse is 17 units.

**CHECK Your Progress**

Find the length of the hypotenuse of each right triangle. If necessary, round to the nearest hundredth.

**1A.**  $a = 7, b = 13, c = ?$

**1B.**  $a = 10, b = 6, c = ?$

**EXAMPLE Find the Length of a Side**

- 2** Find the length of the missing side. If necessary, round to the nearest hundredth.

$$c^2 = a^2 + b^2 \quad \text{Pythagorean Theorem}$$

$$25^2 = a^2 + 10^2 \quad b = 10 \text{ and } c = 25$$

$$625 = a^2 + 100 \quad \text{Evaluate squares.}$$

$$525 = a^2 \quad \text{Subtract 100 from each side.}$$

$$\pm\sqrt{525} = a \quad \text{Use a calculator to evaluate } \sqrt{525}.$$

$$22.91 \approx a \quad \text{Use the positive value.}$$

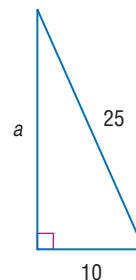
**CHECK Your Progress**

**2A.**  $a = 6, c = 14, b = ?$

**2B.**  $b = 11, c = 21, a = ?$

A group of three whole numbers that satisfy the Pythagorean Theorem is called a **Pythagorean triple**. Examples include (3, 4, 5) and (5, 12, 13). Multiples of Pythagorean triples also satisfy the Pythagorean Theorem, so (6, 8, 10) and (10, 24, 26) are also Pythagorean triples.

**STANDARDIZED TEST EXAMPLE Pythagorean Triples**

- 3** What is the area of triangle  $ABC$ ?

A 96 units<sup>2</sup>

C 120 units<sup>2</sup>

B 160 units<sup>2</sup>

D 196 units<sup>2</sup>

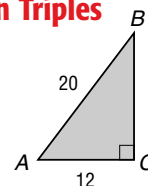
**Read the Test Item**

The area of a triangle is  $A = \frac{1}{2}bh$ . In a right triangle, the legs are the base and height. Use the given measures to find the height.

**Solve the Test Item**

- Step 1** Check to see if the measurements are a multiple of a common Pythagorean triple. The hypotenuse is  $4 \cdot 5$  units, and the leg is  $4 \cdot 3$  units. This triangle is a multiple of a (3, 4, 5) triangle.

$$4 \cdot 3 = 12 \quad 4 \cdot 4 = 16 \quad 4 \cdot 5 = 20 \quad \text{The height is 16 units.}$$

- Step 2** Find the area of the triangle.

$$A = \frac{1}{2}bh \quad \text{Area of a triangle}$$

$$A = \frac{1}{2} \cdot 12 \cdot 16 \quad b = 12 \text{ and } h = 16$$

$$A = 96 \quad \text{Choice A is correct.}$$

**CHECK Your Progress**

- 3.** A square shopping center has a diagonal walkway from one corner to another. If the walkway is about 70 meters long, what is the approximate length of each side of the center?

F 8 meters

G 35 meters

H 50 meters

J 100 meters

**Online Personal Tutor at [algebra1.com](http://algebra1.com)**

**Test-Taking Tip**

Memorize common Pythagorean triples and check for multiples such as (6, 8, 10). This will save you time on the test. Some other common triples are (8, 15, 17) and (7, 24, 25).

**Right Triangles** If you exchange the hypothesis and conclusion of an if-then statement, the result is the **converse** of the statement. The following theorem, the converse of the Pythagorean Theorem, can be used to determine whether a triangle is a right triangle.

## Study Tip

### Converses

Converses of theorems are not necessarily true. But the converse of the Pythagorean Theorem is true.

## KEY CONCEPT

### Converse of the Pythagorean Theorem

If  $a$  and  $b$  are measures of the shorter sides of a triangle,  $c$  is the measure of the longest side, and  $c^2 = a^2 + b^2$ , then the triangle is a right triangle. If  $c^2 \neq a^2 + b^2$ , then the triangle is not a right triangle.

## EXAMPLE Check for Right Triangles

**4** Determine whether the following side measures form right triangles.

a. 20, 21, 29

Since the measure of the longest side is 29, let  $c = 29$ ,  $a = 20$ , and  $b = 21$ . Then determine whether  $c^2 = a^2 + b^2$ .

$$c^2 = a^2 + b^2 \quad \text{Pythagorean Theorem}$$

$$29^2 \stackrel{?}{=} 20^2 + 21^2 \quad a = 20, b = 21, \text{ and } c = 29$$

$$841 \stackrel{?}{=} 400 + 441 \quad \text{Multiply.}$$

$$841 = 841 \quad \text{Add.}$$

Since  $c^2 = a^2 + b^2$ , the triangle is a right triangle.

b. 8, 10, 12

Since the measure of the longest side is 12, let  $c = 12$ ,  $a = 8$ , and  $b = 10$ . Then determine whether  $c^2 = a^2 + b^2$ .

$$c^2 = a^2 + b^2 \quad \text{Pythagorean Theorem}$$

$$12^2 \stackrel{?}{=} 8^2 + 10^2 \quad a = 8, b = 10, \text{ and } c = 12$$

$$144 \stackrel{?}{=} 64 + 100 \quad \text{Multiply.}$$

$$144 \neq 164 \quad \text{Add.}$$

Since  $c^2 \neq a^2 + b^2$ , the triangle is not a right triangle.

## CHECK Your Progress

**4A.** 9, 12, 16

**4B.** 18, 24, 30

## CHECK Your Understanding

**Examples 1, 2**  
(pp. 549–550)

If  $c$  is the measure of the hypotenuse of a right triangle, find each missing measure. If necessary, round to the nearest hundredth.

1.  $a = 10$ ,  $b = 24$ ,  $c = ?$

2.  $a = 11$ ,  $c = 61$ ,  $b = ?$

3.  $b = 13$ ,  $c = \sqrt{233}$ ,  $a = ?$

4.  $a = 7$ ,  $b = 4$ ,  $c = ?$



Find the length of each missing side. If necessary, round to the nearest hundredth.

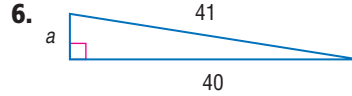
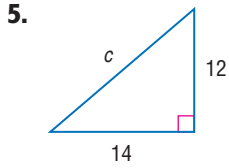

**Example 3**  
(p. 550)

7. **STANDARDIZED TEST PRACTICE** In right triangle  $XYZ$ , the length of  $\overline{YZ}$  is 6, and the length of the hypotenuse is 8. Find the area of the triangle.

- A  $6\sqrt{7}$  units<sup>2</sup>    B 30 units<sup>2</sup>    C 40 units<sup>2</sup>    D 48 units<sup>2</sup>

**Example 4**  
(p. 551)

Determine whether the following side measures form right triangles. Justify your answer.

8. 4, 6, 9

9. 10, 24, 26

## Exercises

For Exercises	See Examples
10–27	1, 2
28–29	3
30–35	4

If  $c$  is the measure of the hypotenuse of a right triangle, find each missing measure. If necessary, round to the nearest hundredth.

10.  $a = 16, b = 63, c = ?$

11.  $a = 16, c = 34, b = ?$

12.  $b = 3, a = \sqrt{112}, c = ?$

13.  $a = \sqrt{15}, b = \sqrt{10}, c = ?$

14.  $c = 14, a = 9, b = ?$

15.  $a = 6, b = 3, c = ?$

16.  $b = \sqrt{77}, c = 12, a = ?$

17.  $a = 4, b = \sqrt{11}, c = ?$

18.  $a = \sqrt{225}, b = \sqrt{28}, c = ?$

19.  $a = \sqrt{31}, c = \sqrt{155}, b = ?$

20.  $a = 8x, b = 15x, c = ?$

21.  $b = 3x, c = 7x, a = ?$

Find the length of each missing side. If necessary, round to the nearest hundredth.

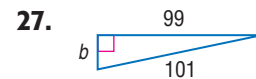
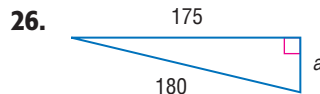
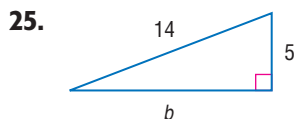
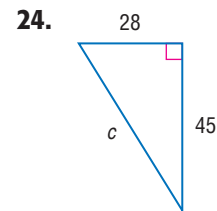
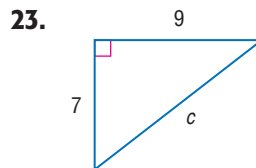
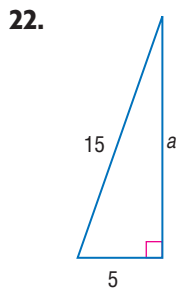

**GEOMETRY** For Exercises 28 and 29, refer to the triangle.

28. What is the length of side  $a$ ?

29. Find the area of the triangle.

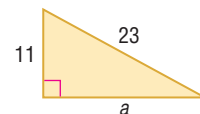

Determine whether the following side measures form right triangles. Justify your answer.

30. 30, 40, 50

31. 6, 12, 18

32. 24, 30, 36

33. 45, 60, 75

34. 15,  $\sqrt{31}$ , 16

35. 4, 7,  $\sqrt{65}$



**Real-World Link**

**Fastest, Tallest, Largest Drop:** *Kingda Ka*, Jackson, New Jersey; 128 mph, 456 ft, and 418 ft, respectively

**Longest:** *Millennium Force*, Sandusky, Ohio; 6,595 ft

**Source:**  
ultimaterollercoaster.com

Find the length of the hypotenuse. Round to the nearest hundredth.

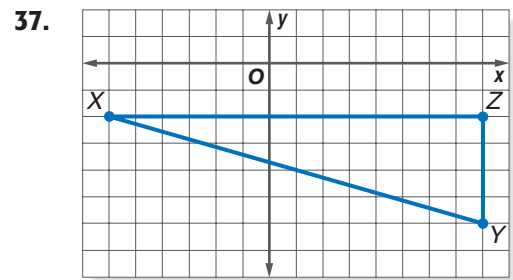
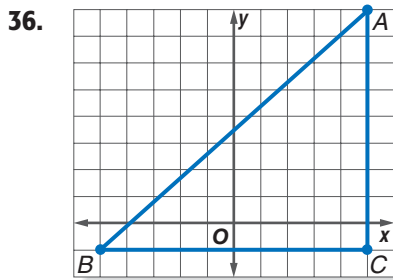

**ROLLER COASTERS** For Exercises 38–40, use the following information.

Suppose a roller coaster climbs 208 feet higher than its starting point making a horizontal advance of 360 feet. When it comes down, it makes a horizontal advance of 44 feet.

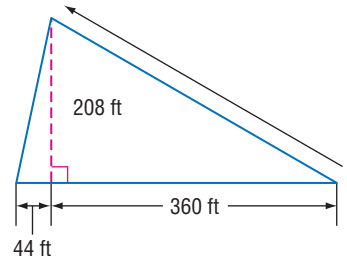

38. How far will it travel to get to the top of the ride?

39. How far will it travel on the downhill track?

40. Compare the total horizontal advance, vertical height, and total track length.

41. **RESEARCH** Use the Internet or other reference to find the measurements of your favorite roller coaster or a roller coaster that is in an amusement park close to you. Draw a model of the first drop. Include the height of the hill, length of the vertical drop, and steepness of the hill.

42. **SAILING** A sailboat's mast and boom form a right angle. The sail itself, called a *mainsail*, is in the shape of a right triangle. If the edge of the mainsail that is attached to the mast is 100 feet long and the edge of the mainsail that is attached to the boom is 60 feet long, what is the length of the longest edge of the mainsail?

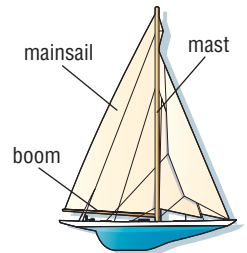

Solve each problem. If necessary, round to the nearest hundredth.

43. Find the length of a diagonal of a square if its area is 162 square feet.

44. A right triangle has one leg that is 5 centimeters longer than the other leg. The hypotenuse is 25 centimeters long. Find the length of each leg of the triangle.

45. Find the length of the diagonal of a cube if each side of the cube is 4 inches long.

46. The ratio of the length of the hypotenuse to the length of the *shorter* leg in a right triangle is 8:5. The hypotenuse measures 144 meters. Find the length of the *longer* leg.

47. **ROOFING** A garage roof is 30 feet long and hangs an additional 2 feet over the walls. How many square feet of shingles are needed for the entire roof?

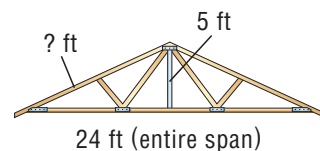
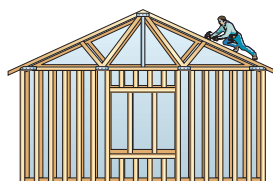

**EXTRA PRACTICE**  
See pages 738, 753.

**Math online**  
Self-Check Quiz at [algebra1.com](http://algebra1.com)

**H.O.T. Problems**

48. **OPEN ENDED** Draw and label a right triangle with legs and hypotenuse with rational lengths. Draw a second triangle with legs of irrational lengths and a hypotenuse of rational length.
49. **CHALLENGE** Compare the area of the largest semicircle to the areas of the two smaller semicircles at the right.
50. *Writing in Math* Use the information on page 549 to explain how the Pythagorean Theorem can be used in designing roller coasters. How are the height, speed, and steepness of a roller coaster related?

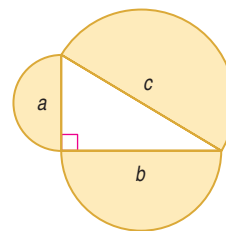

**STANDARDIZED TEST PRACTICE**

51. If the perimeter of square 1 is 160 units and the perimeter of square 2 is 120 units, what is the perimeter of square 3?
- A 100 units  
B 200 units  
C 250 units  
D 450 units

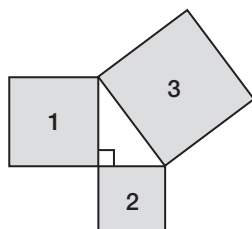

52. **REVIEW** Sara says that if  $x$  is a real number then any value of  $n\sqrt[n]{x^n} = x$ , but Jamal says that this is not always true. Which values could Sara use to prove that she is right?
- F  $x = 4$  and  $n = 2$   
G  $x = 5$  and  $n = -3$   
H  $x = 7$  and  $n = 1$   
J  $x = 3$  and  $n = 2$

**Spiral Review**

Solve each equation. Check your solution. (Lesson 10-3)

53.  $\sqrt{y} = 12$

54.  $3\sqrt{s} = 126$

55.  $4\sqrt{2v+1} - 3 = 17$

Simplify. (Lesson 10-2)

56.  $\sqrt{72}$

57.  $7\sqrt{z} - 10\sqrt{z}$

58.  $\sqrt{\frac{3}{7}} + \sqrt{21}$

59. **AVIATION** Flying with the wind, a plane travels 300 miles in 40 minutes. Flying against the wind, it travels 300 miles in 45 minutes. Find its air speed. (Lesson 5-4)

Write an equation in function notation for each relation. (Lesson 3-5)

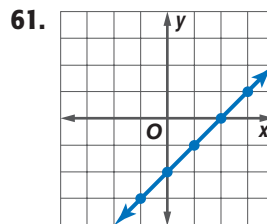
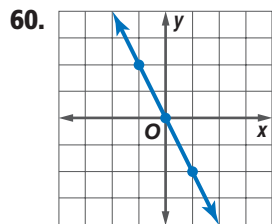

**GET READY for the Next Lesson**

**PREREQUISITE SKILL** Simplify each expression. (Lesson 10-1)

62.  $\sqrt{(6-3)^2 + (8-4)^2}$

63.  $\sqrt{(10-4)^2 + (13-5)^2}$

64.  $\sqrt{(5-3)^2 + (2-9)^2}$

**Main Ideas**

- Find the distance between two points on the coordinate plane.
- Find a point that is a given distance from a second point on a plane.

**New Vocabulary**

Distance Formula

**GET READY for the Lesson**

A certain helicopter can fly 450 miles before it needs to refuel. Suppose a person needs to be flown from a hospital in Washington, North Carolina, to one in Huntington, West Virginia. Each side of a square is 50 miles. If Asheville, North Carolina, is at the origin, Huntington is at  $(0, 196)$ , and Washington is at  $(310, 0)$ , can the helicopter make the trip one way without refueling?



**The Distance Formula** You can find the distance between any two points in the coordinate plane using the **Distance Formula**, which is based on the Pythagorean Theorem.

**KEY CONCEPT***The Distance Formula*

**Words** The distance  $d$  between any two points with coordinates  $(x_1, y_1)$  and  $(x_2, y_2)$  is given by

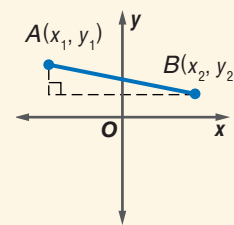
$$d = \sqrt{(x_2 - x_1)^2 + (y_2 - y_1)^2}.$$
**Model****EXAMPLE** Distance Between Two Points

- 1 Find the distance between the points at  $(2, 3)$  and  $(-4, 6)$ .

$$\begin{aligned}
 d &= \sqrt{(x_2 - x_1)^2 + (y_2 - y_1)^2} && \text{Distance Formula} \\
 &= \sqrt{(-4 - 2)^2 + (6 - 3)^2} && (x_1, y_1) = (2, 3) \text{ and } (x_2, y_2) = (-4, 6) \\
 &= \sqrt{(-6)^2 + 3^2} && \text{Simplify.} \\
 &= \sqrt{45} && \text{Evaluate squares and simplify.} \\
 &= 3\sqrt{5} \text{ or about } 6.71 \text{ units}
 \end{aligned}$$

**CHECK Your Progress**

1. Find the distance between the points at  $(4, -1)$  and  $(-2, -5)$ .





### Real-World Link

There are four major tournaments that make up the "grand slam" of golf: Masters, U.S. Open, British Open, and PGA Championship. At age 24, Tiger Woods became the youngest player to win the four major events (called a career grand slam).

Source: PGA

## Real-World EXAMPLE

- 2 GOLF** Tracy's golf ball is 20 feet short and 8 feet to the right of the cup. On her first putt, the ball lands 2 feet to the left and 3 feet beyond the cup. If the ball went in a straight line, how far did it go?

Model the situation. If the cup is at  $(0, 0)$ , then the location of the ball is  $(8, -20)$ . The location after the first putt is  $(-2, 3)$ .

$$\begin{aligned} d &= \sqrt{(x_2 - x_1)^2 + (y_2 - y_1)^2} && \text{Distance Formula} \\ &= \sqrt{(-2 - 8)^2 + [3 - (-20)]^2} && (x_1, y_1) = (8, -20), \\ & && (x_2, y_2) = (-2, 3) \\ &= \sqrt{(-10)^2 + 23^2} && \text{Simplify.} \\ &= \sqrt{629} \text{ or about } 25 \end{aligned}$$

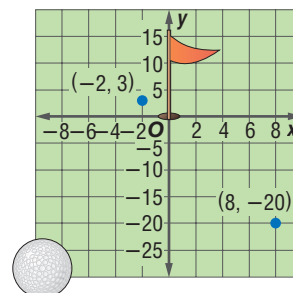

The ball traveled about 25 feet on her first putt.

### CHECK Your Progress

- 2.** Shelly hit the golf ball 12 feet past the hole and 3 feet to the left. Her first putt traveled to 2 feet beyond the cup and 1 foot to the right. How far did the ball travel on her first putt?

**Find Coordinates** Suppose you know the coordinates of a point, one coordinate of another point, and the distance between the two points. You can use the Distance Formula to find the missing coordinate.

## EXAMPLE Find a Missing Coordinate

- 3** Find the possible values of  $a$  if the distance between the points at  $(7, 5)$  and  $(a, -3)$  is 10 units.

$$\begin{aligned} d &= \sqrt{(x_2 - x_1)^2 + (y_2 - y_1)^2} && \text{Distance Formula} \\ 10 &= \sqrt{(a - 7)^2 + (-3 - 5)^2} && \text{Let } x_2 = a, x_1 = 7, y_2 = -3, y_1 = 5, \text{ and } d = 10. \\ 10 &= \sqrt{(a - 7)^2 + (-8)^2} && \text{Simplify.} \\ 10 &= \sqrt{a^2 - 14a + 49 + 64} && \text{Evaluate squares.} \\ 10 &= \sqrt{a^2 - 14a + 113} && \text{Simplify.} \\ 100 &= a^2 - 14a + 113 && \text{Square each side.} \\ 0 &= a^2 - 14a + 13 && \text{Subtract 100 from each side.} \\ 0 &= (a - 1)(a - 13) && \text{Factor.} \\ a - 1 = 0 & \text{ or } & a - 13 = 0 && \text{Zero Product Property} \\ a = 1 & & a = 13 && \text{The value of } a \text{ is 1 or 13.} \end{aligned}$$

### CHECK Your Progress

- 3.** Find the value of  $a$  if the distance between the points at  $(3, a)$  and  $(-4, 5)$  is  $\sqrt{58}$  units.

online Personal Tutor at [algebra1.com](http://algebra1.com)

## CHECK Your Understanding

**Example 1**  
(p. 555)

Find the distance between each pair of points with the given coordinates. Express in simplest radical form and as decimal approximations rounded to the nearest hundredth, if necessary.

1.  $(5, -1), (11, 7)$
2.  $(3, 7), (-2, -5)$
3.  $(2, 2), (5, -1)$
4.  $(-3, -5), (-6, -4)$

**Example 2**  
(p. 556)

5. **GEOMETRY** An isosceles triangle has two sides of equal length. Determine whether  $\triangle ABC$  with vertices  $A(-3, 4)$ ,  $B(5, 2)$ , and  $C(-1, -5)$  is isosceles.

**FOOTBALL** For Exercises 6 and 7, use the information at the right.

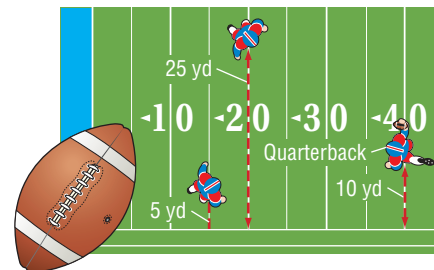

6. A quarterback can throw the football to one of the two receivers. Find the distance from the quarterback to each receiver.
7. What is the distance between the two receivers?

**Example 3**  
(p. 556)

Find the possible values of  $a$  if the points with the given coordinates are the indicated distance apart.

8.  $(3, -1), (a, 7); d = 10$
9.  $(10, a), (1, -6); d = \sqrt{145}$

## Exercises

HOMEWORK	HELP
For Exercises	See Examples
10–17	1
18–23	2
24–29	3

Find the distance between each pair of points whose coordinates are given. Express in simplest radical form and as decimal approximations rounded to the nearest hundredth, if necessary.

10.  $(12, 3), (-8, 3)$
11.  $(0, 0), (5, 12)$
12.  $(6, 8), (3, 4)$
13.  $(-4, 2), (4, 17)$
14.  $(-3, 8), (5, 4)$
15.  $(9, -2), (3, -6)$
16.  $(-8, -4), (-3, -8)$
17.  $(2, 7), (10, -4)$

18. **FREQUENT FLYERS** To determine the mileage between cities for their frequent flyer programs, some airlines superimpose a coordinate grid over the United States. The units of this grid are approximately equal to 0.316 mile. So, a distance of 3 units on the grid equals an actual distance of  $3(0.316)$  or 0.948 mile. Suppose the locations of two airports are at  $(132, 428)$  and  $(254, 105)$ . Find the actual distance between these airports to the nearest mile.

**COLLEGE** For Exercises 19 and 20, use the map of a college campus.

19. Kelly has her first class in Rhodes Hall and her second class in Fulton Lab. How far does she have to walk between her first and second classes?
20. She has 12 minutes between the end of her first class and the start of her second class. If she walks an average of 3 miles per hour, will she make it to her second class on time?

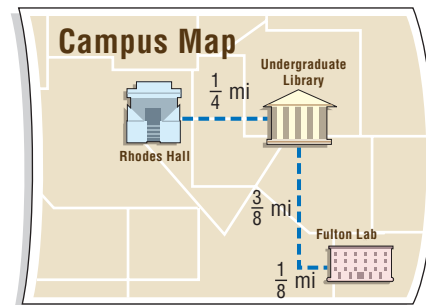

**GEOGRAPHY** For Exercises 21–23, use the map at the right that shows part of Minnesota and Wisconsin.

A coordinate grid has been superimposed on the map with the origin at St. Paul. The grid lines are 20 miles apart. Minneapolis is at  $(-7, 3)$ .



21. Estimate the coordinates for Duluth, St. Cloud, Eau Claire, and Rochester.
22. Find the distance between the following pairs of cities: Minneapolis and St. Cloud, St. Paul and Rochester, Minneapolis and Eau Claire, and Duluth and St. Cloud.
23. A radio station in St. Paul has a range of 75 miles. Which cities shown can receive the broadcast?

Find the possible values of  $a$  if the points with the given coordinates are the indicated distance apart.

24.  $(4, 7), (a, 3); d = 5$
25.  $(-4, a), (4, 2); d = 17$
26.  $(5, a), (6, 1); d = \sqrt{10}$
27.  $(a, 5), (-7, 3); d = \sqrt{29}$
28.  $(6, -3), (-3, a); d = \sqrt{130}$
29.  $(20, 5), (a, 9); d = \sqrt{340}$
30. **GEOMETRY** Triangle  $ABC$  has vertices  $A(7, -4), B(-1, 2)$ , and  $C(5, -6)$ . Determine whether the triangle has three, two, or no sides that are equal in length.
31. **GEOMETRY** If the diagonals of a trapezoid have the same length, then the trapezoid is isosceles. Is trapezoid  $ABCD$  with vertices  $A(-2, 2), B(10, 6), C(9, 8)$ , and  $D(0, 5)$  isosceles? Explain.
32. **GEOMETRY** Triangle  $LMN$  has vertices  $L(-4, -3), M(2, 5)$ , and  $N(-13, 10)$ . If the distance from point  $P(x, -2)$  to  $L$  equals the distance from  $P$  to  $M$ , what is the value of  $x$ ?
33. **GEOMETRY** Plot the points  $Q(1, 7), R(3, 1), S(9, 3)$ , and  $T(7, d)$ . Find the value of  $d$  so that each side of  $QRST$  has the same length.

Find the distance between each pair of points with the given coordinates. Express in simplest radical form and as decimal approximations rounded to the nearest hundredth, if necessary.

34.  $(4, 2), (6, -\frac{2}{3})$
35.  $(5, \frac{1}{4}), (3, 4)$
36.  $(\frac{4}{5}, -1), (2, -\frac{1}{2})$
37.  $(3, \frac{3}{7}), (4, -\frac{2}{7})$
38.  $(4\sqrt{5}, 7), (6\sqrt{5}, 1)$
39.  $(5\sqrt{2}, 8), (7\sqrt{2}, 10)$

**EXTRA PRACTICE**  
See page 738, 753.  
**Math online**  
Self-Check Quiz at [algebra1.com](http://algebra1.com)

**H.O.T. Problems**

40. **OPEN ENDED** Plot two ordered pairs and find the distance between their graphs. Does it matter which ordered pair is first when using the Distance Formula? Explain.
41. **REASONING** Explain why the value calculated under the radical sign in the Distance Formula will never be negative.

42. **REASONING** Explain why there are two values for  $a$  in Example 3. Draw a diagram to support your answer.
43. **CHALLENGE** Plot  $A(-4, 4)$ ,  $B(-7, -3)$ , and  $C(4, 0)$ , and connect them to form triangle  $ABC$ . Demonstrate two different ways to determine whether  $ABC$  is a right triangle.
44. **Writing in Math** Use the information on page 555 to explain how the Distance Formula can be used to find the distance between two cities. Explain how the Distance Formula is derived from the Pythagorean Theorem, and why the helicopter can or cannot make the trip without refueling.



### STANDARDIZED TEST PRACTICE

45. Find the perimeter of a square  $ABCD$  if two of the vertices are  $A(3, 7)$  and  $B(-3, 4)$ .
- A 12 units  
 B  $12\sqrt{5}$  units  
 C  $9\sqrt{5}$  units  
 D 45 units
46. **REVIEW** Helen is making a scale model of her room. She uses a  $\frac{1}{16}$  scale, and the dimensions of her model are  $w = 9$  inches and  $l = 12$  inches. What are the actual dimensions of her room?
- F  $w = 3$  ft and  $l = 4$  ft  
 G  $w = 6\frac{3}{4}$  ft and  $l = 9$  ft  
 H  $w = 12$  ft and  $l = 16$  ft  
 J  $w = 144$  ft and  $l = 192$  ft

### Spiral Review

If  $c$  is the measure of the hypotenuse of a right triangle, find each missing measure. If necessary, round to the nearest hundredth. (Lesson 10-4)

47.  $a = 7, b = 24, c = ?$       48.  $b = 30, c = 34, a = ?$       49.  $a = \sqrt{7}, c = \sqrt{16}, b = ?$

Solve each equation. Check your solution. (Lesson 10-3)

50.  $\sqrt{p-2} + 8 = p$       51.  $\sqrt{r+5} = r - 1$       52.  $\sqrt{5t^2 + 29} = 2t + 3$

Solve each inequality. Then check your solution and graph it on a number line. (Lesson 6-1)

53.  $8 \leq m - 1$       54.  $3 > 10 + k$       55.  $3x \leq 2x - 3$       56.  $s + \frac{1}{6} \leq \frac{2}{3}$

57. **TRAVEL** Two trains leave the station at the same time going in opposite directions. The first train travels south at a speed of 60 miles per hour, and the second train travels north at a speed of 75 miles per hour. How many hours will it take for the trains to be 675 miles apart? (Lesson 2-9)

### GET READY for the Next Lesson

**PREREQUISITE SKILL** Solve each proportion. (Lesson 2-6)

58.  $\frac{x}{4} = \frac{3}{2}$       59.  $\frac{20}{x} = \frac{-5}{2}$       60.  $\frac{6}{9} = \frac{8}{x}$       61.  $\frac{2}{3} = \frac{6}{x+4}$

### Main Ideas

- Determine whether two triangles are similar.
- Find the unknown measures of sides of two similar triangles.

### New Vocabulary

similar triangles

### GET READY for the Lesson

The image of an object being photographed is projected by the camera lens onto the film. The height of the image on the film can be related to the height of the object using similar triangles.

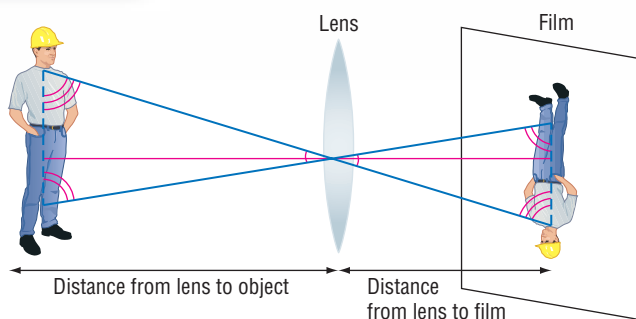

**Similar Triangles** Similar triangles have the same shape, but not necessarily the same size. There are two main tests for similarity.

- If the angles of one triangle and the corresponding angles of a second triangle have equal measures, then the triangles are similar.
- If the measures of the sides of two triangles form equal ratios, or are *proportional*, then the triangles are similar.

The triangles below are similar. The vertices of similar triangles are written in order to show the corresponding parts. So,  $\triangle ABC \sim \triangle DEF$ . The symbol  $\sim$  is read *is similar to*.

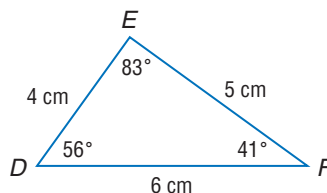
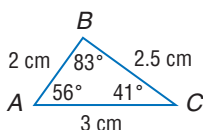

corresponding angles

$$\angle A \text{ and } \angle D$$

$$\angle B \text{ and } \angle E$$

$$\angle C \text{ and } \angle F$$

corresponding sides

$$\overline{AB} \text{ and } \overline{DE} \rightarrow \frac{AB}{DE} = \frac{2}{4} = \frac{1}{2}$$

$$\overline{BC} \text{ and } \overline{EF} \rightarrow \frac{BC}{EF} = \frac{2.5}{5} = \frac{1}{2}$$

$$\overline{AC} \text{ and } \overline{DF} \rightarrow \frac{AC}{DF} = \frac{3}{6} = \frac{1}{2}$$

### KEY CONCEPT

### Similar Triangles

**Words** If two triangles are similar, then the measures of their corresponding sides are proportional, and the measures of their corresponding angles are equal.

**Symbols**  $\triangle ABC \sim \triangle DEF$ , then  $\frac{AB}{DE} = \frac{BC}{EF} = \frac{AC}{DF}$ .

**Model**

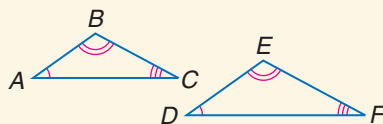

## EXAMPLE Determine Whether Two Triangles Are Similar

- 1 Determine whether the pair of triangles is similar. Justify your answer.

Remember that the sum of the measures of the angles in a triangle is  $180^\circ$ .

The measure of  $\angle P$  is  $180^\circ - (51^\circ + 51^\circ)$  or  $78^\circ$ .

In  $\triangle MNO$ ,  $\angle N$  and  $\angle O$  have the same measure.

Let  $x$  = the measure of  $\angle N$  and  $\angle O$ .

$$x + x + 78^\circ = 180^\circ$$

$$2x = 102^\circ$$

$$x = 51^\circ$$

So  $\angle N = 51^\circ$  and  $\angle O = 51^\circ$ . Since the corresponding angles have equal measures,  $\triangle MNO \sim \triangle PQR$ .

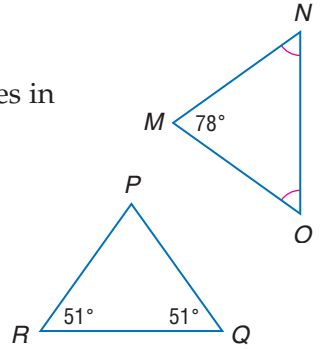

### CHECK Your Progress

1. Determine whether  $\triangle ABC$  with  $m\angle A = 68$  and  $m\angle B = m\angle C$  is similar to  $\triangle DEF$  with  $m\angle E = m\angle F = 56$ . Justify your answer.

**Find Unknown Measures** Proportions can be used to find missing measures of the sides of similar triangles, when some of the measurements are known.

## EXAMPLE Find Missing Measures

- 2 Find the missing measures for each pair of similar triangles.

- a. Since the corresponding angles have equal measures,  $\triangle TUV \sim \triangle WXY$ . The lengths of the corresponding sides are proportional.

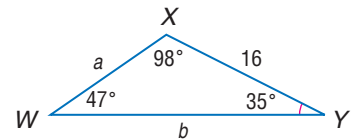
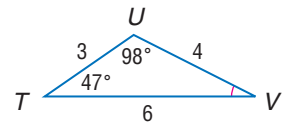

$$\frac{WX}{TU} = \frac{XY}{UV} \quad \text{Corresponding sides of similar triangles are proportional.}$$

$$\frac{a}{3} = \frac{16}{4} \quad WX = a, XY = 16, TU = 3, UV = 4$$

$$4a = 48 \quad \text{Find the cross products.}$$

$$a = 12 \quad \text{Divide each side by 4.}$$

$$\frac{WY}{TV} = \frac{XY}{UV} \quad \text{Corresponding sides of similar triangles are proportional.}$$

$$\frac{b}{6} = \frac{16}{4} \quad WY = b, XY = 16, TV = 6, UV = 4$$

$$4b = 96 \quad \text{Find the cross products.}$$

$$b = 24 \quad \text{Divide each side by 4.}$$

The missing measures are 12 and 24.

### Study Tip

#### Corresponding Vertices

Always use the corresponding order of the vertices to write proportions for similar triangles.

b.  $\triangle ABE \sim \triangle ACD$

$$\frac{BE}{CD} = \frac{AE}{AD}$$

$$\frac{10}{x} = \frac{6}{9}$$

$$90 = 6x$$

$$15 = x$$

$$15^2 + 9^2 = y^2$$

$$\sqrt{306} \text{ or } 17.49 = y$$

Corresponding sides of similar triangles are proportional.

$$BE = 10, CD = x, AE = 6, AD = 9$$

Find the cross products.

Divide each side by 6.

Pythagorean Theorem

Simplify.

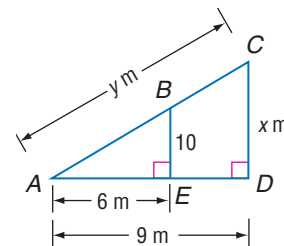

**CHECK Your Progress**

2A.

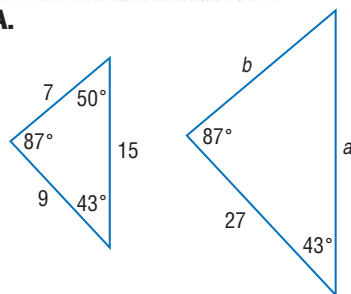

2B.

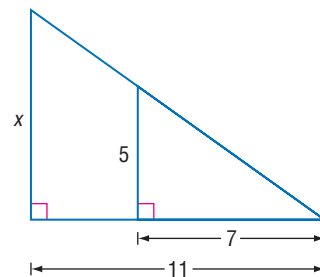

**online** Personal Tutor at [algebra1.com](http://algebra1.com)

**Real-World EXAMPLE**

**3 SHADOWS** Jenelle is standing near the Washington Monument in Washington, D.C. The shadow of the monument is 151.5 feet, and Jenelle's shadow is 1.5 feet. If Jenelle is 5.5 feet tall, how tall is the monument?

The shadows form similar triangles. Write a proportion that compares the heights of the objects and the lengths of their shadows.

Let  $x$  = the height of the monument.

$$\begin{array}{l} \text{Jenelle's shadow} \rightarrow \frac{1.5}{151.5} = \frac{5.5}{x} \leftarrow \text{Jenelle's height} \\ \text{monument's shadow} \rightarrow \frac{1.5}{151.5} = \frac{5.5}{x} \leftarrow \text{monument's height} \end{array}$$

$$1.5x = 833.25 \quad \text{Cross products}$$

$$x = 555.5 \quad \text{Divide each side by 1.5.}$$

The height of the monument is about 555.5 feet.

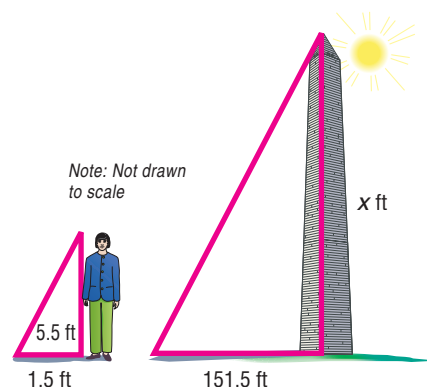

**CHECK Your Progress**

**3.** Jody is trying to follow the directions that explain how to pitch a triangular tent. The directions include a scale drawing where 1 inch = 4.5 feet. In the drawing, the tent is  $1\frac{3}{4}$  inches tall. How tall should the actual tent be?



**Real-World Link**

The monument has a shape of an Egyptian *obelisk*. A pyramid made of solid aluminum caps the top of the monument.

Source: nps.gov

**Example 1**  
(p. 561)

Determine whether each pair of triangles is similar. Justify your answer.

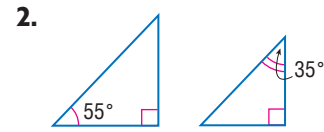
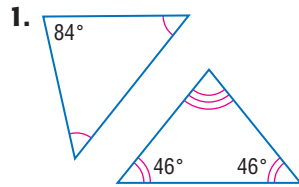

**Example 2**  
(pp. 561–562)

For each set of measures given, find the measures of the missing sides if  $\triangle ABC \sim \triangle DEF$ .

3.  $c = 15, d = 7, e = 9, f = 5$
4.  $a = 18, c = 9, e = 10, f = 6$
5.  $a = 5, d = 7, f = 6, e = 5$
6.  $a = 17, b = 15, c = 10, f = 6$

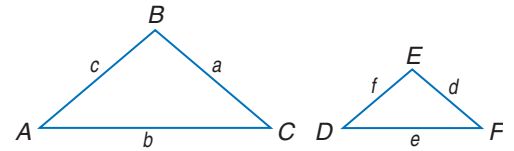

**Example 3**  
(p. 562)

7. **SHADOWS** A 25-foot flagpole casts a shadow that is 10 feet long and the nearby building casts a shadow that is 26 feet long. How tall is the building?

## Exercises

HOMEWORK HELP	
For Exercises	See Examples
8–13	1
14–21	2
22–24	3

Determine whether each pair of triangles is similar. Justify your answer.

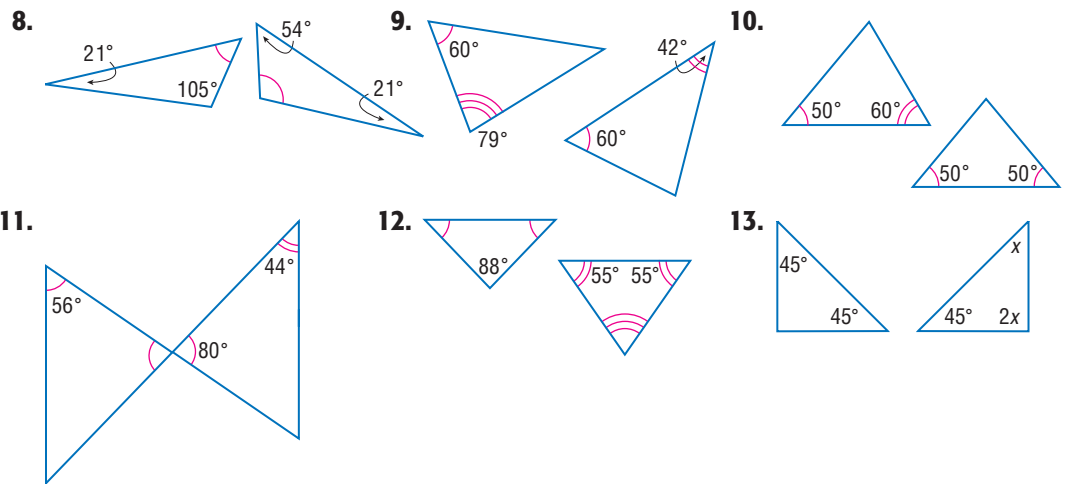

For each set of measures given, find the measures of the missing sides if  $\triangle KLM \sim \triangle NOP$ .

14.  $k = 9, n = 6, o = 8, p = 4$
15.  $k = 24, \ell = 30, m = 15, n = 16$
16.  $m = 11, p = 6, n = 5, o = 4$
17.  $k = 16, \ell = 13, m = 12, o = 7$
18.  $n = 6, p = 2.5, \ell = 4, m = 1.25$
19.  $p = 5, k = 10.5, \ell = 15, m = 7.5$
20.  $n = 2.1, \ell = 4.5, p = 3.2, o = 3.4$
21.  $m = 5, k = 12.6, o = 8.1, p = 2.5$

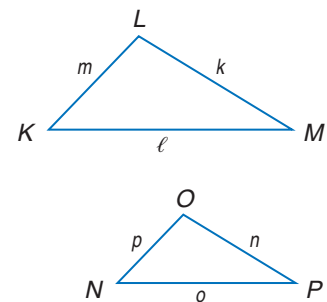

22. **PHOTOGRAPHY** Refer to the diagram of a camera at the beginning of the lesson. Suppose the image of a man who is 2 meters tall is 1.5 centimeters tall on film. If the film is 3 centimeters from the lens of the camera, how far is the man from the camera?



23. **TOYS** Diecast model cars use a scale of 1 inch : 2 feet of the real vehicle. The original vehicle has a window shaped like a right triangle. If the height of the window on the actual vehicle is 2.5 feet, what will the height of the window be on the model?

24. **GOLF** Jessica is playing miniature golf on a hole like the one shown at the right. She wants to putt her ball  $U$  so that it will bank at  $T$  and travel into the hole at  $R$ . Use similar triangles to find where Jessica's ball should strike the wall.

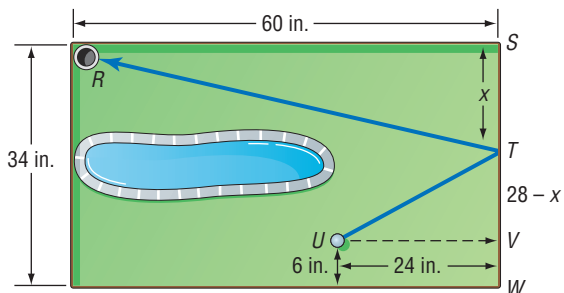

25. **CRAFTS** Melinda is working on a quilt pattern containing isosceles triangles whose sides measure 2 inches, 2 inches, and 2.5 inches. She has several square pieces of material that measure 4 inches on each side. From each square piece, how many triangles with the required dimensions can she cut?

**MIRRORS** For Exercises 26 and 27, use the diagram and the following information.

Viho wanted to measure the height of a nearby building. He placed a mirror on the pavement at point  $P$ , 80 feet from the base of the building. He then backed away until he saw an image of the top of the building in the mirror.

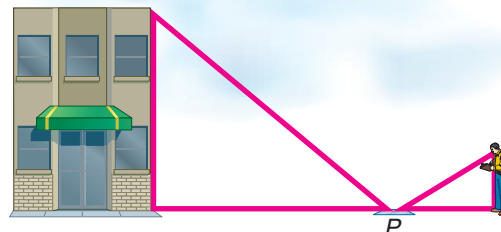

26. If Viho is 6 feet tall and he is standing 9 feet from the mirror, how tall is the building?
27. What assumptions did you make in solving the problem?

**EXTRA PRACTICE**  
See page 738, 753.  
**Math Online**  
Self-Check Quiz at [algebra1.com](http://algebra1.com)

**H.O.T. Problems**

28. **OPEN ENDED** Draw and label a triangle  $ABC$ . Then draw and label a similar triangle  $MNO$  so that the area of  $\triangle MNO$  is four times the area of  $\triangle ABC$ . Explain your strategy.

29. **REASONING** Determine whether the following statement is *sometimes*, *always*, or *never* true. Explain your reasoning.

*If the measures of the sides of a triangle are multiplied by 3, then the measures of the angles of the enlarged triangle will have the same measures as the angles of the original triangle.*

30. **FIND THE ERROR** Russell and Consuela are comparing the similar triangles below to determine their corresponding parts. Who is correct? Explain your reasoning.

Russell  
 $m\angle X = m\angle T$   
 $m\angle Y = m\angle U$   
 $m\angle Z = m\angle V$   
 $\triangle XYZ, \triangle TUV$

Consuela  
 $m\angle X = m\angle V$   
 $m\angle Y = m\angle U$   
 $m\angle Z = m\angle T$   
 $\triangle XYZ, \triangle VUT$

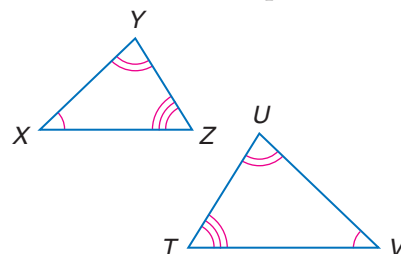

**CRITICAL THINKING** For Exercises 31–33, use the following information.

The radius of one circle is twice the radius of another.

31. Are the circles similar? Explain your reasoning.
32. What is the ratio of their circumferences? Explain your reasoning.
33. What is the ratio of their areas? Explain your reasoning.
34. *Writing in Math* Use the information about photography on page 560 to explain how similar triangles are related to photography. Include an explanation of the effect of moving a camera with a zoom lens closer to the object being photographed and a description of what you could do to fit the entire image of a large object on the picture.



**STANDARDIZED TEST PRACTICE**

35. Which is a true statement about the figure?

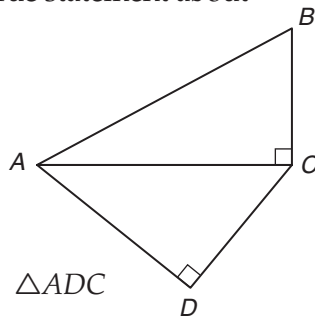

- A  $\triangle ABC \sim \triangle ADC$
- B  $\triangle ABC \sim \triangle ACD$
- C  $\triangle ABC \sim \triangle CAD$
- D none of the above

36. **REVIEW** Kareem needs to know the length and width of his room but does not have a tape measure. He knows that the room is square and that it has an area of 121 square feet. What should Kareem do to find the dimensions of his room?

- F Divide the area by the number of sides.
- G Multiply the area by 2.
- H Square the area.
- J Take the square root of the area.

**Spiral Review**

Find the distance between each pair of points whose coordinates are given. Express answers in simplest radical form and as decimal approximations rounded to the nearest hundredth, if necessary. (Lesson 10-5)

37.  $(1, 8), (-2, 4)$

38.  $(4, 7), (3, 12)$

39.  $(1, 5\sqrt{6}), (6, 7\sqrt{6})$

The lengths of three sides of a triangle are given. Determine whether each triangle is a right triangle. (Lesson 10-4)

40. 25, 60, 65

41. 20, 25, 35

42. 49, 168, 175

Use elimination to solve each system of equations. (Lesson 5-3)

43.  $2x + y = 4$   
 $x - y = 5$

44.  $3x - 2y = -13$   
 $2x - 5y = -5$

45.  $\frac{1}{3}x + \frac{1}{2}y = 8$   
 $\frac{1}{2}x - \frac{1}{4}y = 0$

46. **AVIATION** An airplane passing over Sacramento at an elevation of 37,000 feet begins its descent to land at Reno, 140 miles away. If the elevation of Reno is 4500 feet, what should the approximate slope of descent be? (Hint: 1 mi = 5280 ft) (Lesson 4-1)

# READING MATH

## The Language of Mathematics

The language of mathematics is a specific one, but it borrows from everyday language, scientific language, and world languages. To find a word's correct meaning, you will need to be aware of some confusing aspects of language.

Confusing Aspect	Words
Some words are used in English and in mathematics, but have distinct meanings.	factor, <b>leg</b> , prime, power, <b>rationalize</b>
Some words are used in English and in mathematics, but the mathematical meaning is more precise.	difference, even, <b>similar</b> , slope
Some words are used in science and in mathematics, but the meanings are different.	divide, <b>radical</b> , solution, variable
Some words are only used in mathematics.	decimal, <b>hypotenuse</b> , integer, quotient
Some words have more than one mathematical meaning.	base, <b>degree</b> , range, round, square
Sometimes several words come from the same root word.	polygon and polynomial, <b>radical</b> and <b>radicand</b>
Some mathematical words sound like English words.	<b>sum</b> and some, whole and hole, base and bass

Words in boldface are in this chapter.

## Reading to Learn

- How do the mathematical meanings of the following words compare to the everyday meanings?
  - factor
  - leg
  - rationalize
- State two mathematical definitions for each word. Give an example for each definition.
  - degree
  - range
  - round
- Each word below is shown with its root word and the root word's meaning. Find three additional words that come from the same root.
  - domain, from the root word *domus*, which means house
  - radical, from the root word *radix*, which means root
  - similar, from the root word *similis*, which means like





## FOLDABLES™

Study Organizer

## GET READY to Study

Be sure the following  
Key Concepts are noted  
in your Foldable.

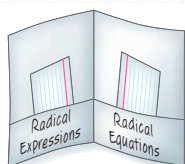

## Key Concepts

## Simplifying Radical Expressions

(Lesson 10-1)

- A radical expression is in simplest form when
- no radicands have perfect square factors other than 1,
- no radicands contain fractions,
- and no radicands appear in the denominator of a fraction.

Operations with Radical Expressions  
and Equations (Lessons 10-2 and 10-3)

- Radical expressions with like radicands can be added or subtracted.
- Use the FOIL Method to multiply radicand expressions.
- Solve radical equations by isolating the radical on one side of the equation. Square each side of the equation to eliminate the radical.

Pythagorean Theorem and Distance  
Formula (Lessons 10-4 and 10-5)

- If  $a$  and  $b$  are the measures of the legs of a right triangle and  $c$  is the measure of the hypotenuse, then  $c^2 = a^2 + b^2$ .
- If  $a$  and  $b$  are measures of the shorter sides of a triangle,  $c$  is the measure of the longest side, and  $c^2 = a^2 + b^2$ , then the triangle is a right triangle.
- The distance  $d$  between any two points with coordinates  $(x_1, y_1)$  and  $(x_2, y_2)$  is given by  $d = \sqrt{(x_2 - x_1)^2 + (y_2 - y_1)^2}$ .

## Similar Triangles (Lesson 10-6)

- Similar Triangles have congruent corresponding angles and proportional corresponding sides.  
If  $\triangle ABC \sim \triangle DEF$ , then  $\frac{AB}{DE} = \frac{BC}{EF} = \frac{AC}{DF}$ .

## Key Vocabulary

- conjugate (p. 531)  
converse (p. 551)  
Distance Formula (p. 555)  
extraneous solution (p. 542)  
hypotenuse (p. 549)  
leg (p. 549)  
Pythagorean triple (p. 550)  
radical equation (p. 541)  
radical expression (p. 528)  
radicand (p. 528)  
rationalizing the denominator (p. 530)  
similar triangles (p. 560)

## Vocabulary Check

State whether each sentence is *true* or *false*.  
If *false*, replace the underlined word or number to make a true sentence.

1. The binomials  $-3 + \sqrt{7}$  and  $3 - \sqrt{7}$  are conjugates.
2. In the expression  $-4\sqrt{5}$ , the radicand is 5.
3. The longest side of a right triangle is the hypotenuse.
4. After the first step in solving  $\sqrt{3x + 19} = x + 3$ , you would have  $3x + 19 = x^2 + 9$ .
5. The two sides that form the right angle in a right triangle are called the legs of the triangle.
6. The expression  $\frac{2x\sqrt{3x}}{\sqrt{6y}}$  is in simplest radical form.
7. A triangle with sides having measures of 25, 20, and 15 is a right triangle.
8. Two triangles are similar if the corresponding angles are congruent.

## Lesson-by-Lesson Review

**10-1** Simplifying Radical Expressions (pp. 528–534)

Simplify.

9.  $\sqrt{\frac{60}{y^2}}$

10.  $\sqrt{44a^2b^5}$

11.  $(3 - 2\sqrt{12})^2$

12.  $\frac{9}{3 + \sqrt{2}}$

13.  $\frac{2\sqrt{7}}{3\sqrt{5} + 5\sqrt{3}}$

14.  $\frac{\sqrt{3a^3b^4}}{\sqrt{8ab^{10}}}$

15. **METEOROLOGY** To estimate how long a thunderstorm will last, meteorologists use the formula  $t = \sqrt{\frac{d^3}{216}}$ , where  $t$  is time in hours and  $d$  is the diameter of the storm in miles. A storm is 10 miles in diameter. How long will it last?

**Example 1** Simplify  $\frac{3}{5 - \sqrt{2}}$ .

$$\frac{3}{5 - \sqrt{2}}$$

$$= \frac{3}{5 - \sqrt{2}} \cdot \frac{5 + \sqrt{2}}{5 + \sqrt{2}}$$

Rationalize the denominator.

$$= \frac{3(5) + 3\sqrt{2}}{5^2 - (\sqrt{2})^2}$$

$$(a - b)(a + b) = a^2 - b^2$$

$$= \frac{15 + 3\sqrt{2}}{25 - 2}$$

$$(\sqrt{2})^2 = 2$$

$$= \frac{15 + 3\sqrt{2}}{23}$$

Simplify.

**10-2** Operations with Radical Expressions (pp. 536–540)

Simplify each expression.

16.  $2\sqrt{3} + 8\sqrt{5} - 3\sqrt{5} + 3\sqrt{3}$

17.  $2\sqrt{6} - \sqrt{48}$

18.  $4\sqrt{7k} - 7\sqrt{7k} + 2\sqrt{7k}$

19.  $\sqrt{8} + \sqrt{\frac{1}{8}}$

Find each product.

20.  $\sqrt{2}(3 + 3\sqrt{3})$

21.  $(\sqrt{3} - \sqrt{2})(2\sqrt{2} + \sqrt{3})$

22.  $(6\sqrt{5} + 2)(3\sqrt{2} + \sqrt{5})$

23. **MOTION** The velocity of a dropped object can be found using  $v = \sqrt{2gd}$ , where  $v$  is the velocity in feet per second,  $g$  is the acceleration due to gravity, and  $d$  is the distance in feet the object drops. Find the speed of a penny when it hits the ground, after being dropped off the Eiffel Tower. Use 32 feet per second squared for  $g$  and 984 feet for the height of the Eiffel Tower.

**Example 2**  $\sqrt{6} - \sqrt{54} + 3\sqrt{12} + 5\sqrt{3}$ .

$$\sqrt{6} - \sqrt{54} + 3\sqrt{12} + 5\sqrt{3}$$

$$= \sqrt{6} - \sqrt{3^2 \cdot 6} + 3\sqrt{2^2 \cdot 3} + 5\sqrt{3}$$

$$= \sqrt{6} - (\sqrt{3^2} \cdot \sqrt{6}) + 3(\sqrt{2^2} \cdot \sqrt{3}) + 5\sqrt{3}$$

$$= \sqrt{6} - 3\sqrt{6} + 3(2\sqrt{3}) + 5\sqrt{3}$$

$$= \sqrt{6} - 3\sqrt{6} + 6\sqrt{3} + 5\sqrt{3}$$

$$= -2\sqrt{6} + 11\sqrt{3}$$

**Example 3** Find  $(2\sqrt{3} - \sqrt{5})(\sqrt{10} + 4\sqrt{6})$ .

$$(2\sqrt{3} - \sqrt{5})(\sqrt{10} + 4\sqrt{6})$$

$$= (2\sqrt{3})(\sqrt{10}) + (2\sqrt{3})(4\sqrt{6})$$

$$+ (-\sqrt{5})(\sqrt{10}) + (-\sqrt{5})(4\sqrt{6})$$

$$= 2\sqrt{30} + 8\sqrt{18} - \sqrt{50} - 4\sqrt{30}$$

$$= 2\sqrt{30} + 8\sqrt{3^2 \cdot 2} - \sqrt{5^2 \cdot 2} - 4\sqrt{30}$$

$$= -2\sqrt{30} + 19\sqrt{2}$$

**10-3 Radical Equations** (pp. 541-546)

Solve each equation. Check your solution.

24.  $10 + 2\sqrt{b} = 0$       25.  $\sqrt{a + 4} = 6$   
 26.  $\sqrt{7x - 1} = 5$       27.  $\sqrt{\frac{4a}{3}} - 2 = 0$   
 28.  $\sqrt{x + 4} = x - 8$       29.  $\sqrt{3x - 14} + x = 6$

30. **FREE FALL** Assuming no air resistance, the time  $t$  in seconds that it takes an object to fall  $h$  feet can be determined by  $t = \frac{\sqrt{h}}{4}$ . If a skydiver jumps from an airplane and free falls for 8 seconds before opening the parachute, how many feet does the skydiver fall?

**Example 4** Solve  $\sqrt{5 - 4x} - 6 = 7$ .

$$\begin{aligned} \sqrt{5 - 4x} - 6 &= 7 && \text{Original equation} \\ \sqrt{5 - 4x} &= 13 && \text{Add 6 to each side.} \\ 5 - 4x &= 169 && \text{Square each side.} \\ -4x &= 164 && \text{Subtract 5 from each side.} \\ x &= -41 && \text{Divide each side by } -4. \end{aligned}$$

**10-4 The Pythagorean Theorem** (pp. 549-554)

If  $c$  is the measure of the hypotenuse of a right triangle, find each missing measure. If necessary, round answers to the nearest hundredth.

31.  $a = 30, b = 16, c = ?$   
 32.  $b = 4, c = 56, a = ?$   
 33.  $a = 6, b = 10, c = ?$   
 34.  $a = 10, c = 15, b = ?$   
 35.  $a = 18, c = 30, b = ?$   
 36.  $a = 1.2, b = 1.6, c = ?$

Determine whether the following side measures form right triangles.

37. 9, 16, 20      38. 20, 21, 29  
 39. 9, 40, 41      40. 18,  $\sqrt{24}$ , 30

41. **MOVING** The door of Julio's apartment measures 7 feet high and 3 feet wide. Julio would like to buy a square table that is 7 feet on a side. If the table cannot go through the door sideways, will it fit diagonally? Explain.

**Example 5** Find the length of the missing side.

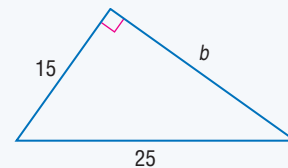

$$\begin{aligned} c^2 &= a^2 + b^2 && \text{Pythagorean Theorem} \\ 25^2 &= 15^2 + b^2 && c = 25 \text{ and } a = 15 \\ 625 &= 225 + b^2 && \text{Evaluate squares.} \\ 400 &= b^2 && \text{Subtract 225 from each side.} \\ 20 &= b && \text{Take the square root of each side.} \end{aligned}$$

**Example 6** Determine whether the side measures, 6, 10, and 12, form a right triangle.

$$\begin{aligned} c^2 &= a^2 + b^2 && \text{Pythagorean Theorem} \\ 12^2 &\stackrel{?}{=} 6^2 + 10^2 && a = 6, b = 10, \text{ and } c = 12 \\ 144 &\stackrel{?}{=} 36 + 100 && \text{Multiply.} \\ 144 &\neq 136 && \text{Add. These side measures do not form a right triangle.} \end{aligned}$$

**10-5** The Distance Formula (pp. 555-559)

Find the distance between each pair of points with the given coordinates. Express in simplest radical form and as decimal approximations rounded to the nearest hundredth if necessary.

42.  $(9, -2), (1, 13)$     43.  $(4, 2), (7, 9)$   
 44.  $(4, 8), (-7, 12)$     45.  $(-2, 6), (5, 11)$

Find the value of  $a$  if the points with the given coordinates are the indicated distance apart.

46.  $(-3, 2), (1, a); d = 5$   
 47.  $(5, -2), (a, -3); d = \sqrt{170}$   
 48. **SAILING** A boat leaves the harbor and sails 5 miles east and 3 miles north to an island. The next day, they travel to a fishing spot 10 miles south and 4 miles west of the harbor. How far is it from the fishing spot to the island?

**Example 7** Find the distance between the points with coordinates  $(-5, 1)$  and  $(1, 5)$ .

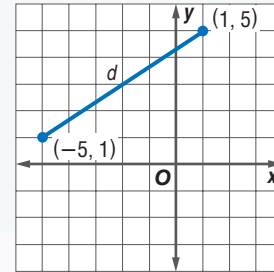

Use the Distance Formula.

$$\begin{aligned} d &= \sqrt{(x_2 - x_1)^2 + (y_2 - y_1)^2} \\ &= \sqrt{(1 - (-5))^2 + (5 - 1)^2} \\ &= \sqrt{6^2 + 4^2} && \text{Simplify.} \\ &= \sqrt{36 + 16} && \text{Evaluate squares.} \\ &= \sqrt{52} \text{ or about } 7.21 \text{ units} && \text{Simplify.} \end{aligned}$$

**10-6** Similar Triangles (pp. 560-565)

For each set of measures given, find the measures of the remaining sides if  $\triangle ABC \sim \triangle DEF$ .

49.  $c = 16, b = 12, a = 10, f = 9$   
 50.  $a = 8, c = 10, b = 6, f = 12$   
 51.  $c = 12, f = 9, a = 8, e = 11$   
 52.  $b = 20, d = 7, f = 6, c = 15$

53. **HOUSES** Josh plans to make a model of his house in the scale 1 inch = 6 feet. If the height to the top of the roof on the house is 24 feet, what will the height of the model be?



**Example 8** Find the measure of side  $a$  if the two triangles are similar.

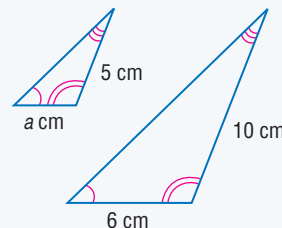

$$\begin{aligned} \frac{10}{5} &= \frac{6}{a} && \text{Corresponding sides of similar} \\ &&& \text{triangles are proportional.} \\ 10a &= 30 && \text{Find the cross products.} \\ a &= 3 && \text{Divide each side by 10.} \end{aligned}$$

Simplify.

1.  $2\sqrt{27} - 4\sqrt{3}$       2.  $\sqrt{6} + \sqrt{\frac{2}{3}}$   
 3.  $\sqrt{6}(4 + \sqrt{12})$       4.  $\sqrt{\frac{10}{3}} \cdot \sqrt{\frac{4}{30}}$   
 5.  $(1 - \sqrt{3})(3 + \sqrt{2})$       6.  $\sqrt{112x^4y^6}$

Solve each equation. Check your solution.

7.  $\sqrt{10x} = 20$       8.  $\sqrt{4s} + 1 = 11$   
 9.  $\sqrt{4x + 1} = 5$       10.  $x = \sqrt{-6x - 8}$   
 11.  $x = \sqrt{5x + 14}$       12.  $\sqrt{4x - 3} = 6 - x$

If  $c$  is the measure of the hypotenuse of a right triangle, find each missing measure. If necessary, round to the nearest hundredth.

13.  $a = 8, b = 10, c = ?$   
 14.  $a = 6\sqrt{2}, c = 12, b = ?$   
 15. **DISC GOLF** The sport of disc golf is similar to golf except that the players throw a disc into a basket instead of hitting a ball into a cup. Bob's first disc lands 10 feet short and 12 feet to the left of the basket. On his next throw, the disc lands 5 feet to the right and 2 feet beyond the basket. Assuming that the disc traveled in a straight line, how far did the disc travel on the second throw?

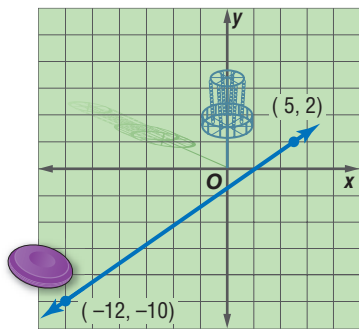

16. **SPORTS** A hiker leaves her camp in the morning. How far is she from camp after walking 9 miles due west and then 12 miles due north?

Find the distance between each pair of points with the given coordinates. Express in simplest radical form and as decimal approximations rounded to the nearest hundredth, if necessary.

17.  $(4, 7), (4, -2)$   
 18.  $(-1, 1), (1, -5)$   
 19.  $(-9, 2), (21, 7)$

For each set of measures given, find the measures of the missing sides if  $\triangle ABC \sim \triangle JKH$ .

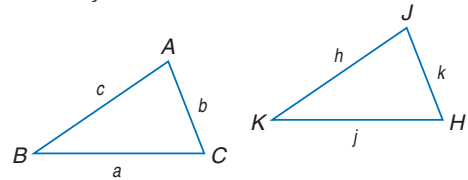

20.  $c = 20, h = 15, k = 16, j = 12$   
 21.  $c = 12, b = 13, a = 6, h = 10$   
 22.  $k = 5, c = 6.5, b = 7.5, a = 4.5$   
 23.  $h = 1\frac{1}{2}, c = 4\frac{1}{2}, k = 2\frac{1}{4}, a = 3$   
 24. **MULTIPLE CHOICE** Find the area of the rectangle.

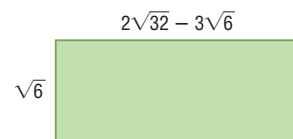

- A  $2\sqrt{32} - 18$  units<sup>2</sup>  
 B  $16\sqrt{2} - 4\sqrt{6}$  units<sup>2</sup>  
 C  $16\sqrt{3} - 18$  units<sup>2</sup>  
 D  $32\sqrt{3} - 18$  units<sup>2</sup>  
 25. **SHADOWS** Suppose you are standing near the flag pole in front of your school and you want to know its height. The flag pole casts a 22-foot shadow. You cast a 3-foot shadow. If you are 5 feet tall, how tall is the flag pole?



## Standardized Test Practice

Cumulative, Chapters 1–10

Read each question. Then fill in the correct answer on the answer document provided by your teacher or on a sheet of paper.

1. Aliyah is creating two flower beds in her yard. She wants the rectangles to be similar. Using the dimensions given, find the approximate length of the side labeled  $x$ .

- A 8 feet  
B 15 feet  
C 20 feet  
D 50 feet

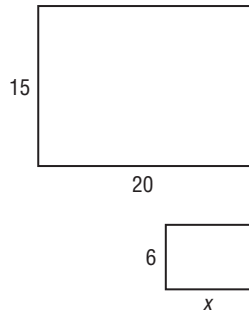

2. What is the area of the square in the diagram?

- F  $4.2 \text{ units}^2$   
G  $9 \text{ units}^2$   
H  $8.4 \text{ units}^2$   
J  $18 \text{ units}^2$

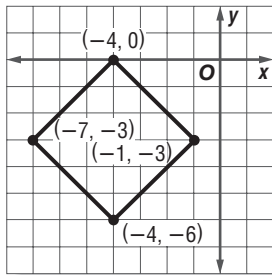

3. **GRIDDABLE** Carol must earn more than \$360 from selling boxes of oranges in order to go on a trip with the student council. If each box is sold for \$12.50, what is the least number of boxes that she must sell?

4. The number of jazz CDs that Vince owns  $j$  is 4 less than the number of pop CDs  $p$  that he owns. Which equation represents the number of pop CDs he owns?

- A  $j = p + 4$   
B  $p = j - 4$   
C  $p = j + 4$   
D  $p = 4j$

5. Matt, Nate, and Mark are walking to meet each other at a corner. At one point, Matt is at the corner, Nate is 60 feet from Matt, and Mark is 20 feet from Matt. About how far is Mark from Nate?

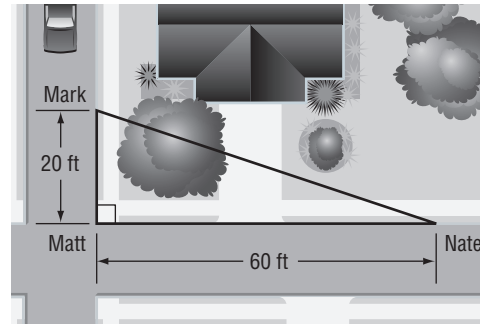

- F 6 ft    G 57 ft    H 63 ft    J 80 ft

6. Which linear function includes the points at  $(-4, 7)$  and  $(4, 5)$ ?

- A  $f(x) = -4x + 6$   
B  $f(x) = -\frac{1}{4}x - \frac{9}{4}$   
C  $f(x) = \frac{1}{4}x - 6$   
D  $f(x) = -\frac{1}{4}x + 6$

## TEST-TAKING TIP

**QUESTION 6** When you write an equation, check that the given values make a true statement. For example, in Question 6, substitute the values of the coordinates  $(-4, 7)$  into your equation to check.

7. If  $\triangle ABC$  is similar to  $\triangle DEF$ , what is the length of  $y$ ?

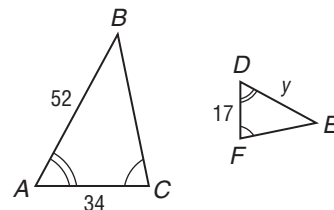

- F 11.1    G 17    H 26    J 104

8. The perimeter  $p$  of a square may be found by using the formula  $\left(\frac{1}{4}\right)p = \sqrt{a}$ , where  $a$  is the area of the square. What is the perimeter of the square with an area of 64 square feet?

A 2  
B 12  
C 32  
D 64

9. Ms. Milo's classroom is square, with sides that are 20 feet long. What is the approximate distance from one corner of the room to the other corner diagonally?

F 10 ft    G 20 ft    H 25 ft    J 28 ft

10. Kayla wants to build a square cement patio in the corner of her yard as pictured below. What will be the area of the cement patio?

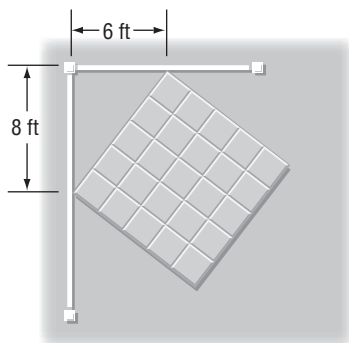

A  $10 \text{ ft}^2$                       C  $64 \text{ ft}^2$   
B  $16 \text{ ft}^2$                       D  $100 \text{ ft}^2$

11. What property was used to simplify the expression  $\frac{1}{4}(8x - 12) = 2x - 3$ ?

F Distributive Property  
G Associative Property  
H Commutative Property  
J Not here

12. **GRIDDABLE** The coordinate grid below shows three squares.

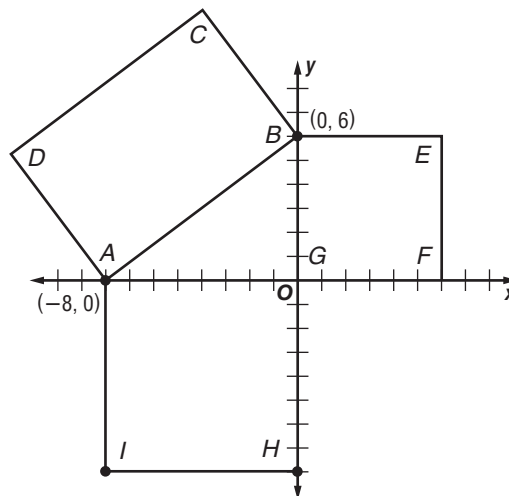

Which value best represents the area of square  $ABCD$  in square units?

**Pre-AP**

**Record your answers on a sheet of paper. Show your work.**

13. Haley hikes 3 miles north, 7 miles east, and then 6 miles north again.
- Draw a diagram showing the direction and distance of each segment of Haley's hike. Label Haley's starting point, her ending point, and the distance, in miles, of each segment of her hike.
  - To the nearest tenth of a mile, how far (in a straight line) is Haley from her starting point?
  - How did your diagram help you to find Haley's distance from her starting point?
  - Describe the direction and distance of Haley's return trip back to her starting position if she used the same trail.

**NEED EXTRA HELP?**

If You Missed Question...

Go to Lesson or Page...

1	2	3	4	5	6	7	8	9	10	11	12	13
10-6	10-5	6-2	2-1	10-4	4-4	10-6	10-3	10-4	10-4	1-2	10-4	10-4

